

ACTUATION

AND CONTROLS | CATALOG

ACCA9000

"Apollo" Valves
Made In The USA



5 YEAR
WARRANTY
ON ALL DOMESTIC MADE PRODUCT

SECTION R – ACTUATION

Table of Contents

DESCRIPTION	PAGE
<u>PNEUMATIC RACK AND PINION ACTUATORS</u>	
Apollo® AD (Double Acting) & AS (Spring Return), Sizes 0025 thru 0350	R 3-8
Apollo® AD (Double Acting) & AS (Spring Return), Sizes 0600 thru 4000	R 9-15
Actuator Inserts for AD & AS, Sizes 0025 thru 1600.....	R-16
Apollo® Acutorque Rack and Pinion (stainless steel)	R 17-22
Scotch Yoke, G-Series.....	R 23-27
<u>ELECTRIC ACTUATORS</u>	
AE Series.....	R 28-31
CS & CL Series.....	R 32-35
LB Series	R 36-38
<u>ACCESSORIES</u>	
Apollo® Solenoid Valves, Stonel & Moniteur Limit Switch Assemblies.....	R 39-42
VRC Positioners.....	R-43
VRC Positioners.....	R-44
Proximity Valve Position Monitoring System.....	R-45
OSHA Lockout Target Device.....	R-46
<u>OTHER</u>	
Apollo® Ball Valve Information.....	R 47-52
Apollo® Butterfly Valve Information.....	R 53-54
Warranty and Limitations of Liability.....	R-55

AD & AS ACTUATORS

Sizes 0025 to 0350

APOLLO RACK & PINION

Designed and manufactured for the ultimate in durability and reliability, the new Apollo® Pneumatic Rack & Pinion Actuators provide outstanding service life.

Apollo Rack & Pinion actuators have replaceable insert drive adapters in all but the largest models, and many units have dual "F" series bolt patterns. The numerous actuator drive and bolt pattern combinations allow direct mounting of several valve styles.

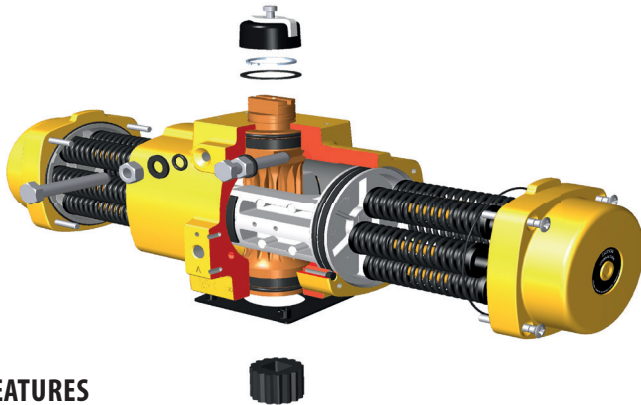

FEATURES

- 1. Cast Aluminum Body**
Yellow Chromate Powder Coat Finish
- 2. Die Cast Aluminum End Caps**
Yellow Chromate Powder Coat Finish
- 3. Die Cast Aluminum Pistons**
Hard Anodized
- 4. Aluminum Alloy Pinion**
Hard-coat Anodized Finish
- 5. Drive Inserts**
Extruded Aluminum
Hard-coat Anodized Finish
- 6. Preloaded Concentric Springs**
Delta-Tone® Coated
- 7. Bushings**
Polyoxymethylene (POM)
- 8. O-Ring Seals**
Standard Temp. (-4°F to 180°F): Buna-N
High Temp. (-4°F to 250°F): Fluorocarbon
Low Temp. (-40°F to 180°F): Silicone
- 9. Capscrews, Nuts & Other Hardware**
Stainless Steel or Delta-Tone® Coated

BENEFITS

- Compact Rack & Pinion Design
- Quarter-Turn Operation
- Designed for use on a variety of Valve Types:
Ball Valves, Butterfly Valves, Plug Valves
- Applicable to Damper and Door Openers
- Both Double-Acting and Spring-Return Units
- Double-Acting Torque Outputs from 220 in-lbs to 3547 in-lbs with an 80 psi Air Supply
- Removable/Replaceable Drive Inserts*
- Pre-loaded Spring Assemblies
- ISO 5211 Valve Mounting
- NAMUR (VDI/VDE 3845) Accessory Mounts
- ATEX Classification II, 2 GD, Zones 1 or 2 (Gases) and 21 or 22 (Dust)
- Anti Blow-Out Pinion Design
- Maximum Pressure Rating: 116 psig (8 bar)
- Compatible Media: Clean, Dry Air, Filtered Non-corrosive Gas or Light Hydraulic Oil
- Pre-lubricated for the life of the Actuator
- Chromate Corrosion Protection on all Aluminum Components
- Each Unit is Serialized
- 5 Year Apollo Warranty**

Notes:

- * A wide selection of standard inserts is available for Square, DIN and Double-D drives.
See page 16.

AD & AS ACTUATORS

Parts List – Sizes 0025 to 0350

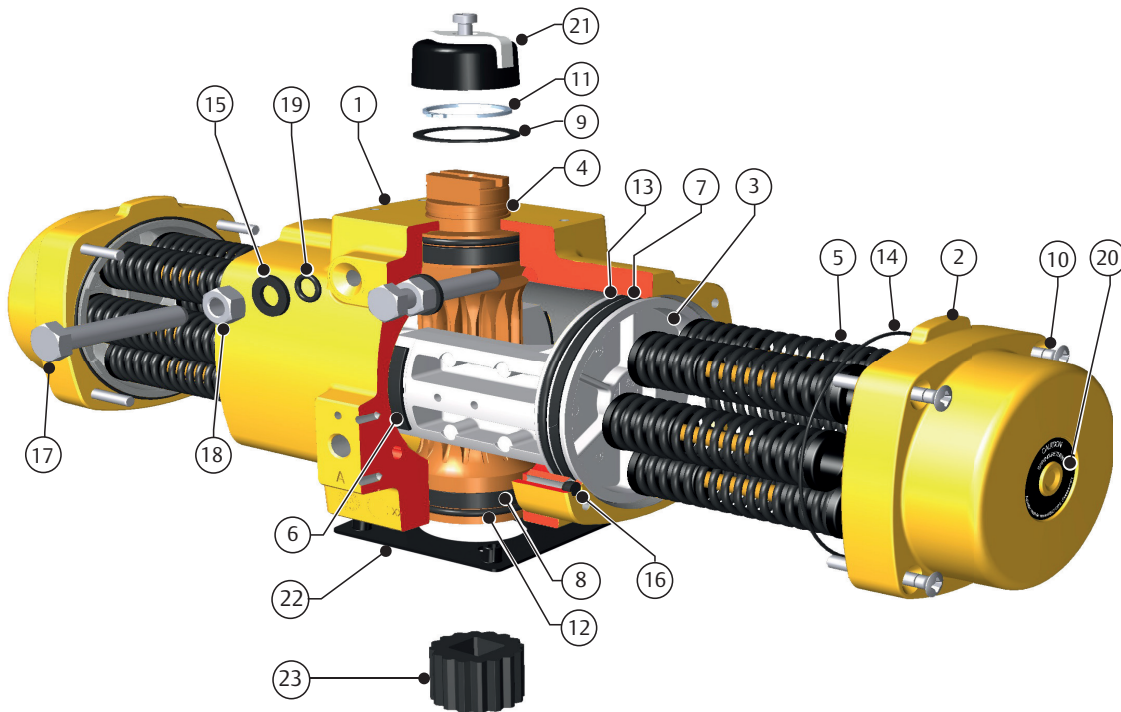

Part	Qty	Description	Material	Notes
1	1	Body	Cast Aluminium alloy	Chromated and polyurethane powder coated
2	2	End cap	Cast Aluminium alloy	Chromated and polyurethane powder coated
3	2	Piston	Cast Aluminium alloy	Chromated
4	1	Pinion	High grade aluminium	Hard anodized
5	Max. 12	Spring cartridge	Spring steel	Electrophoretic coated
6 *	2	Bearing strip piston rack	POM	
7 *	2	Bearing piston	PTFE 25% carbon-filled	
8 *	2	Bearing pinion	POM	
9 *	1	Thrust washer	POM, black UV-stabilized	
10	8	End cap screw	Stainless Steel	
11 *	1	Circlip	Spring steel	Deltatone® coated
12 *	2	O-ring seal pinion	Nitrile rubber	
13 *	2	O-ring seal piston	Nitrile rubber	
14 *	2	O-ring seal end cap	Nitrile rubber	
15 *	2	O-ring seal limit stop	Nitrile rubber	
16 *	2	B-port seal	Silicon rubber	
17	2	Limit stop screw	Stainless steel	
18	2	Limit stop nut	Stainless steel	
19	2	Limit stop washer	PA66	
20	2	Warning sticker	Polyester	
21	1	Indicator assembly	ABS + stainless steel screw	
22	1	Center plate (option)	Nylon PA6, Black	
23	1	Insert drive	Aluminium alloy	

* Included in repair kit

AD & AS ACTUATORS

Dimensional Data – Sizes 0025 to 0350

ENVELOPE DIMENSIONS - SOLENOID INTERFACE - TOP MOUNTING INTERFACE

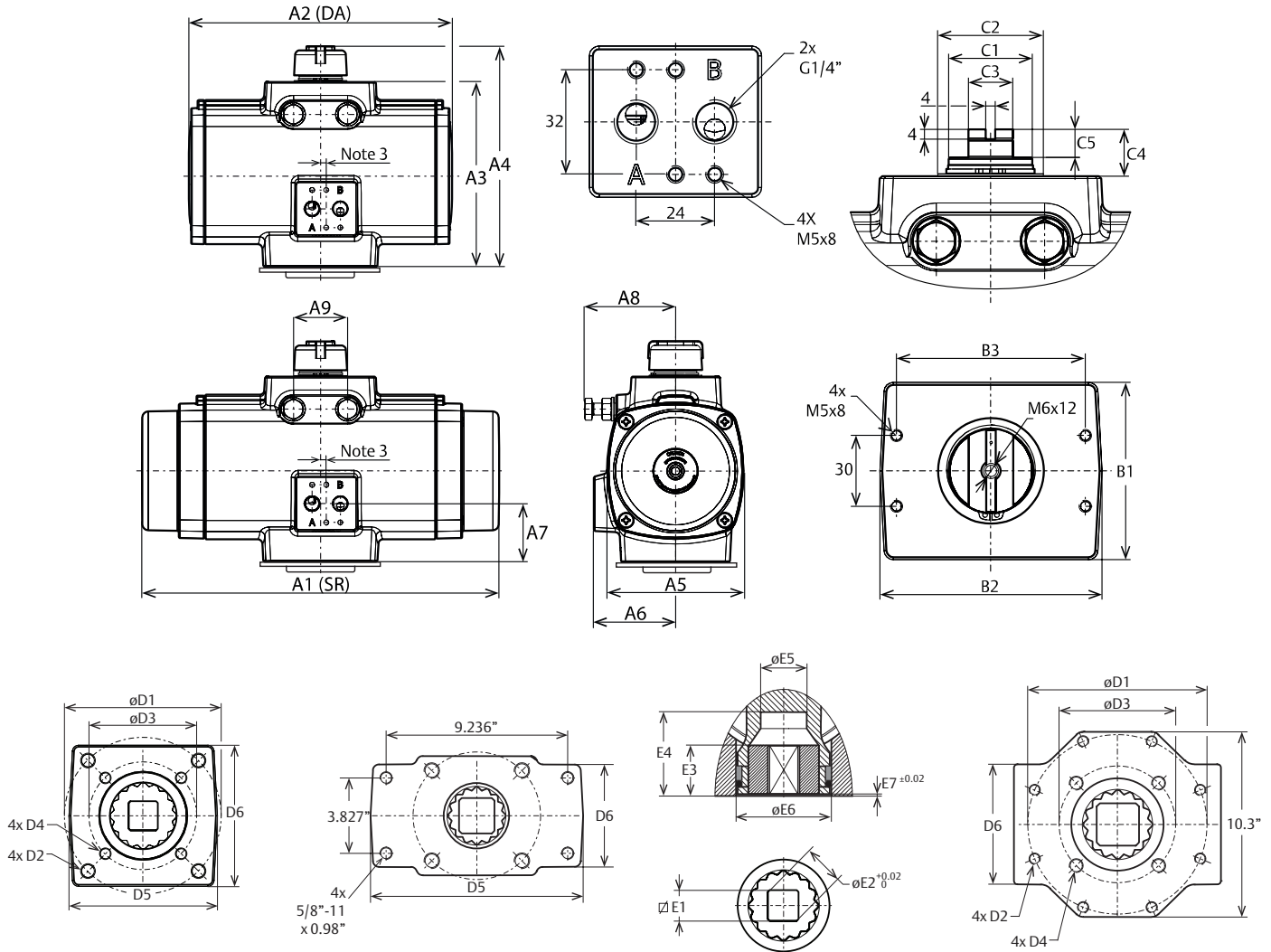

Tolerance limits unless otherwise specified:
 X.X = ± 0.02"
 X.XX = ± 0.01"

Note:

1. DA = Double-Acting, SR = Spring-Return
2. Solenoid interface and top mounting interface according to VDI/VDE3845 (NAMUR)
3. The solenoid drilling pattern is shifted 0.16" for size 0025 and 0.08" for size 0040 vs. the centerline of the actuator.

Dim in Inches	Actuator Size						
	0025	0040	0065	0100	0150	0200	0350
A1	6.54	7.55	8.53	9.72	11.97	14.23	15.15
A2	6.54	7.55	8.53	9.72	8.80	10.07	10.58
A3	3.59	4.39	4.86	5.14	6.19	6.42	7.92
A4	4.69	5.47	5.94	6.22	7.28	7.52	9.06
A5	3.23	3.74	4.09	4.53	5.00	5.28	6.50
A6	1.91	2.15	2.28	2.50	2.72	2.83	3.35
A7	1.16	1.34	1.48	1.50	1.93	1.92	1.65
A8	1.89	2.28	2.72	2.72	2.95	3.43	4.29
A9	0.71	0.98	1.06	1.10	1.81	1.81	1.81

Dim in Inches	Actuator Size						
	0025	0040	0065	0100	0150	0200	0350
B1	1.69	1.77	1.97	2.36	2.95	2.95	3.35
B2	3.70	3.70	3.70	3.82	3.70	3.70	3.94
B3	3.15	3.15	3.15	3.15	3.15	3.15	3.15
C1	0.63	0.87	0.87	0.87	1.34	1.42	1.42
C2	0.91	1.18	1.18	1.18	1.77	1.77	1.77
C3	0.39	0.55	0.55	0.55	0.75	0.75	0.75
C4	0.79	0.79	0.79	0.79	0.79	0.79	0.79
C5	0.47	0.47	0.47	0.47	0.47	0.47	0.47

AD & AS ACTUATORS

Dimensional Data – Sizes 0025 to 0350

VALVE INTERFACE AND DRIVE DETAILS

Note:

1. Flange and square drive according to DIN 3337

Tolerance limits unless otherwise specified:
 X.X = ± 0.02"
 X.XX = ± 0.01"

Size 0025 to 0350

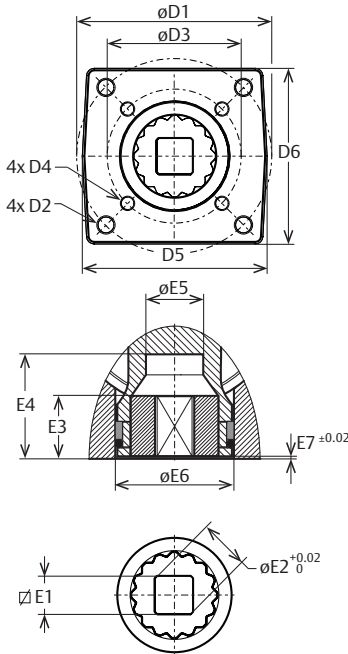

Dim in Inches	Actuator Size						
	0025	0040	0065	0100	0150	0200	0350
ISO 1	F05	F07	F07	F07	F10	F10	F10
D1	1.969	2.756	2.756	2.756	4.016	4.016	4.016
D2	1/4"-20 x0.39"	5/16"-18 x0.39"	5/16"-18 x0.39"	5/16"-18 x0.39"	3/8"-16 x0.63"	3/8"-16 x0.63"	3/8"-16 x0.63"
ISO 2	F03	F05	F05	F05	F07	F07	F07
D3	1.417	1.969	1.969	1.969	2.756	2.756	2.756
D4	10-24 x0.31"	1/4"-20 x0.39"	1/4"-20 x0.39"	1/4"-20 x0.39"	5/16"-18 x0.39"	5/16"-18 x0.39"	5/16"-18 x0.39"
D5	1.97	2.68	2.68	2.62	3.82	3.7	3.7
D6	1.89	2.56	2.56	2.48	3.62	3.54	3.7
E1 Max	0.436	0.554	0.554	0.751	0.751	0.87	1.067
E1 Min	0.433	0.551	0.551	0.748	0.748	0.866	1.063
E2	0.555	0.713	0.713	0.992	1.004	1.11	1.425
E3	0.591	0.591	0.591	0.709	1.083	1.083	1.083
E4	1.34	1.34	1.34	1.34	1.97	1.97	1.97
E5	0.56	0.71	0.83	0.93	1.12	1.26	1.26
E6	0.96	1.36	1.36	1.5	2.22	2.22	2.22
E7	0.02	0.04	0.04	0.04	0.05	0.05	0.05

TORQUE OUTPUT OF DOUBLE ACTING RACK & PINION ACTUATORS (IN - LB)

Actuator Size	Supply Pressure (psi)										
	40	45	50	55	60	70	75	80	90	100	120
AD0025	109	123	137	151	165	193	207	220	248	276	332
AD0040	205	231	257	283	309	361	387	413	466	518	622
AD0065	312	352	392	431	471	550	590	630	709	789	948
AD0100	461	520	579	638	696	814	873	931	1049	1166	1401
AD0150	739	833	927	1021	1115	1304	1398	1492	1680	1868	2244
AD0200	1011	1140	1269	1398	1527	1784	1913	2042	2299	2557	3072
AD0350	1758	1981	2205	2429	2653	3100	3324	3547	3995	4442	5337

Double-Acting Torque Diagram

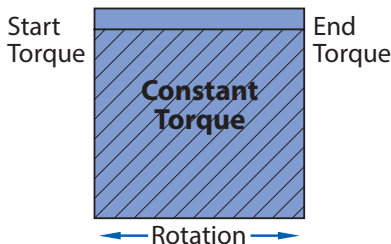

Spring-Return Torque Diagram

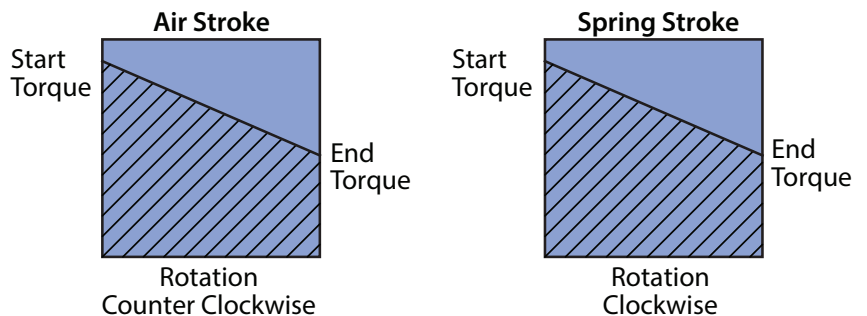

AD & AS ACTUATORS

Torque Output

Actuator Size	Spring Set	Spring Stroke		Air Stroke Supply Pressure (psi)															
				40		50		60		70		80		90		100		120	
		Start	End	Start	End	Start	End	Start	End	Start	End	Start	End	Start	End	Start	End	Start	End
AS0025	▶ 2	63	39	70	44	100	73	129	103	159	132	188	162	218	191	247	221	306	280
	3	94	59	48	8	77	37	107	67	136	96	166	126	195	155	225	185	283	244
	4	125	79	-	-	-	-	84	31	113	60	143	90	172	119	202	149	261	208
	5	156	99	-	-	-	-	-	-	91	24	120	54	150	83	179	113	238	172
	6	188	118	-	-	-	-	-	-	-	-	98	18	127	47	157	77	216	136
AS0040	▶ 2	116	73	133	84	188	139	243	195	299	250	354	305	409	360	464	415	575	526
	3	174	110	91	18	146	73	201	128	257	183	312	239	367	294	422	349	533	459
	4	231	146	-	-	-	-	159	62	214	117	270	172	325	227	380	283	491	393
	5	289	183	-	-	-	-	-	-	172	50	228	106	283	161	338	216	449	327
	6	347	220	-	-	-	-	-	-	-	-	186	39	241	94	296	150	407	260
AS0065	▶ 2	181	114	200	123	284	207	368	291	452	376	537	460	621	544	705	628	873	796
	3	271	171	134	19	219	103	303	188	387	272	471	356	555	440	639	524	808	693
	4	361	228	-	-	-	-	237	84	322	168	406	252	490	336	574	420	742	589
	5	452	285	-	-	-	-	-	-	256	64	340	148	424	232	509	317	677	485
	6	542	341	-	-	-	-	-	-	-	-	275	44	359	129	443	213	612	381
AS0100	▶ 2	262	166	299	188	423	313	548	437	672	562	797	686	921	811	1046	935	1295	1184
	3	392	248	203	38	328	162	452	287	577	411	701	536	826	660	950	785	1199	1034
	4	523	331	-	-	-	-	357	136	482	261	606	385	731	510	855	634	1104	883
	5	654	414	-	-	-	-	-	-	387	110	511	235	636	359	760	484	1009	733
	6	785	497	-	-	-	-	-	-	-	-	416	85	540	209	665	334	914	583
AS0150	▶ 2	416	262	482	304	681	504	881	703	1080	902	1279	1102	1479	1301	1678	1500	2077	1899
	3	625	393	332	65	531	264	730	464	930	663	1129	862	1328	1062	1528	1261	1926	1660
	4	833	524	-	-	-	-	580	224	779	424	979	623	1178	823	1377	1022	1776	1421
	5	1041	654	-	-	-	-	-	-	629	185	828	384	1027	583	1227	783	1626	1181
	6	1249	785	-	-	-	-	-	-	-	-	678	145	877	344	1076	543	1475	942
AS0200	▶ 2	578	364	653	407	926	680	1198	953	1471	1226	1744	1499	2017	1771	2290	2044	2836	2590
	3	867	547	443	75	716	348	989	621	1262	894	1535	1166	1808	1439	2080	1712	2626	2258
	4	1156	729	-	-	-	-	780	289	1052	561	1325	834	1598	1107	1871	1380	2417	1926
	5	1445	911	-	-	-	-	-	-	843	229	1116	502	1389	775	1662	1048	2207	1593
	6	1734	1093	-	-	-	-	-	-	-	-	906	170	1179	443	1452	716	1998	1261
AS0350	▶ 2	990	624	1145	724	1619	1199	2093	1673	2567	2147	3041	2621	3515	3095	3990	3569	4938	4517
	3	1485	936	786	156	1261	630	1735	1104	2209	1578	2683	2052	3157	2526	3631	3000	4579	3948
	4	1979	1248	-	-	-	-	1376	535	1850	1009	2324	1483	2798	1957	3272	2431	4221	3380
	5	2474	1560	-	-	-	-	-	-	1492	440	1966	914	2440	1388	2914	1863	3862	2811
	6	2969	1872	-	-	-	-	-	-	-	-	1607	346	2081	820	2555	1294	3504	2242

▶ STANDARD

AD & AS ACTUATORS

Technical Data – Sizes 0025 to 0350

ACTUATOR WEIGHT

Actuator Size	Double-Acting	Spring-Return
	lbs	lbs
0025	3.1	3.5
0040	4.6	5.1
0065	6.2	7.3
0100	7.7	9.5
0150	10.8	14.6
0200	13.2	18.3
0350	22	32

OPERATING SPEED RESULTS (See test conditions below)

Actuator Size	Cycle Time in Seconds			
	Spring-Return		Double-Acting	
	A-port pressurized	Spring Stroke	A-port pressurized	B-port pressurized
0025	0.5	0.4	0.5	0.4
0040	0.6	0.5	0.6	0.5
0065	0.7	0.5	0.6	0.6
0100	0.8	0.6	0.8	0.7
0150	1.0	0.8	0.9	0.8
0200	1.3	0.9	1.0	1.0
0350	1.9	1.3	1.4	1.5

DISPLACEMENT

Actuator Size	Actuator Volume			Consumption per stroke (cubic inch, pressure in psig)					
	Maximum Volume (cubic inch)			Outward Stroke (Double-Acting & Spring Return)			Inward Stroke (Double-Acting Only)		
	Central ¹ chamber	End cap ² chamber	Displaced ³ volume	40 psig	80 psig	120 psig	40 psig	80 psig	120 psig
0025	6.4	11.8	4.7	23	80	120	40	80	120
0040	10.0	22	8.9	36	64	92	70	131	192
0065	22	34	13.5	74	134	194	107	200	293
0100	22	50	19.9	80	140	200	158	295	433
0150	48	43	32	163	295	427	151	270	389
0200	50	59	44	182	320	458	207	369	532
0350	118	103	76	402	729	1055	359	642	925

NOTES:

1. For Double-acting and Spring-return. Pistons at 90° outward position
2. Only for Double-acting. Pistons at 0° inward position
3. Stroke is 90°

OPERATING SPEED TEST

Solenoid with flow capacity:	0.6 m ³ /hr
Pipe diameter:	6 mm
Medium:	clean air
Supply pressure:	80 psi
Load:	with average load
Stroke:	90°
Temperature:	Room temperature

SELECTING/SIZING APOLLO RACK & PINION ACTUATORS

Establish the valve operating torque beginning with the torque constants for the appropriate pressure and valve as found on pages 49-51. Use the torque adjustment factors found on page 52 to arrive at an in-service torque. Multiple adjustment factors may be required. Do not forget to include adjustments for graphite stem packing.

FOR DOUBLE ACTING ACTUATORS

Based on the available air supply select an actuator with torque outputs that exceed the in-service torque by at least 10%.

FOR SPRING RETURN ACTUATORS

Considering the available air supply, select an actuator where both the Spring-Ending torque figure and the Air-Ending torque figure exceeds the in-service torque by at least 10%.

How to Order Apollo Pneumatic Rack & Pinion Actuators – New AD and AS

APOLLO RACK & PINION NUMBERING SYSTEM

A	S	0350	N	04	A	C	A
PREFIX	ACTION	SIZE	SEAL OPTION	SPRING SET	INSERTS	FAIL POSITION	REVISION
A	D = DOUBLE ACTING S = SPRING RETURN K = KIT	0025 0040 0065 0100 0150 0200 0350	N = NITRILE H = FLOUROCARBON L = SILICONE	00 (DA) 02 03 04 05 06 08	A = STANDARD SQUARE B = WITHOUT INSERT	C = FAIL CLOSED (FC) F = FAIL OPEN (FO) D = NO SPRING	A



AD & AS ACTUATORS

Sizes 0600 to 1600

APOLLO RACK & PINION

Designed and manufactured for the ultimate in durability and reliability, the new Apollo® Pneumatic Rack & Pinion Actuators provide outstanding service life.

Apollo Rack & Pinion actuators have replaceable insert drive adapters in all but the largest models, and many units have dual "F" series bolt patterns. The numerous actuator drive and bolt pattern combinations allow direct mounting of several valve styles.

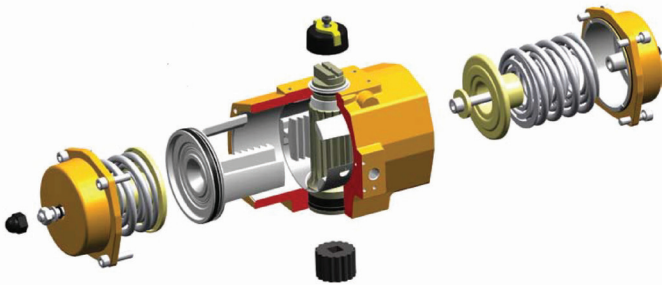

FEATURES

- 1. Cast Aluminum Body**
Yellow Chromate Powder Coat Finish
- 2. Die Cast Aluminum End Caps**
Yellow Chromate Powder Coat Finish
- 3. Die Cast Aluminum Pistons**
Hard Anodized
- 4. Aluminum Alloy Pinion**
7075-T6
Hard-coat Anodized Finish
- 5. Drive Inserts**
Extruded Aluminum
Hard-coat Anodized Finish
- 6. Preloaded Concentric Springs**
Deltatone® Coated
- 7. Piston Guides**
Molybdenum Disulfide filled Polyamide
- 8. Bushings**
Polyoxymethylene (POM)
- 9. O-Ring Seals**
Standard Temp. (-4°F to 180°F): Buna-N
High Temp. (-4°F to 250°F): Fluorocarbon
Low Temp. (-40°F to 180°F): Silicone
- 10. Capscrews, Nuts & Other Hardware**
304 Stainless Steel

BENEFITS

- Compact Rack & Pinion Design
- Quarter-Turn Operation
- Designed for use on a variety of Valve Types:
Ball Valves, Butterfly Valves, Plug Valves
- Applicable to Damper and Door Openers
- Both Single Stop and Double Stop Versions**
- Both Double-Acting and Spring-Return Units
- Double-Acting Torque Outputs from 6028 in-lbs to 40293 in-lbs with an 80 psi Air Supply
- Removable/Replaceable Drive Inserts*



- Pre-loaded Spring Assemblies
- ISO 5211 Valve Mounting
- NAMUR (VDI/VDE) Accessory Mounts
- ATEX Classification II, 2 GD, Zones 1 or 2
(Gases) and 21 or 22 (Dust)
- Anti Blow-Out Pinion Design
- Maximum Pressure Rating: 116 psig (8 bar)
- Compatible Media: Clean, Dry Air, Filtered
Non-corrosive Gas or Light Hydraulic Oil
- Pre-lubricated for the life of the Actuator
- Chromate Corrosion Protection on all Aluminum
Components
- Each Unit is Serialized
- 5 Year Apollo Warranty**

Notes:

* A wide selection of standard inserts is available for Square, DIN and Double-D drives.

** Single Stop units are used where the open position of the valve requires precise adjustment. These are standard on all actuators with the exception of the two larger sizes where single stops are optional. Actuators with dual adjustable stops are also available for those applications on butterfly valves, for example, to allow precise adjustment of both the open and closed positions. Refer to page 16.

AD & AS ACTUATORS

Parts List – Sizes 0600 to 1600

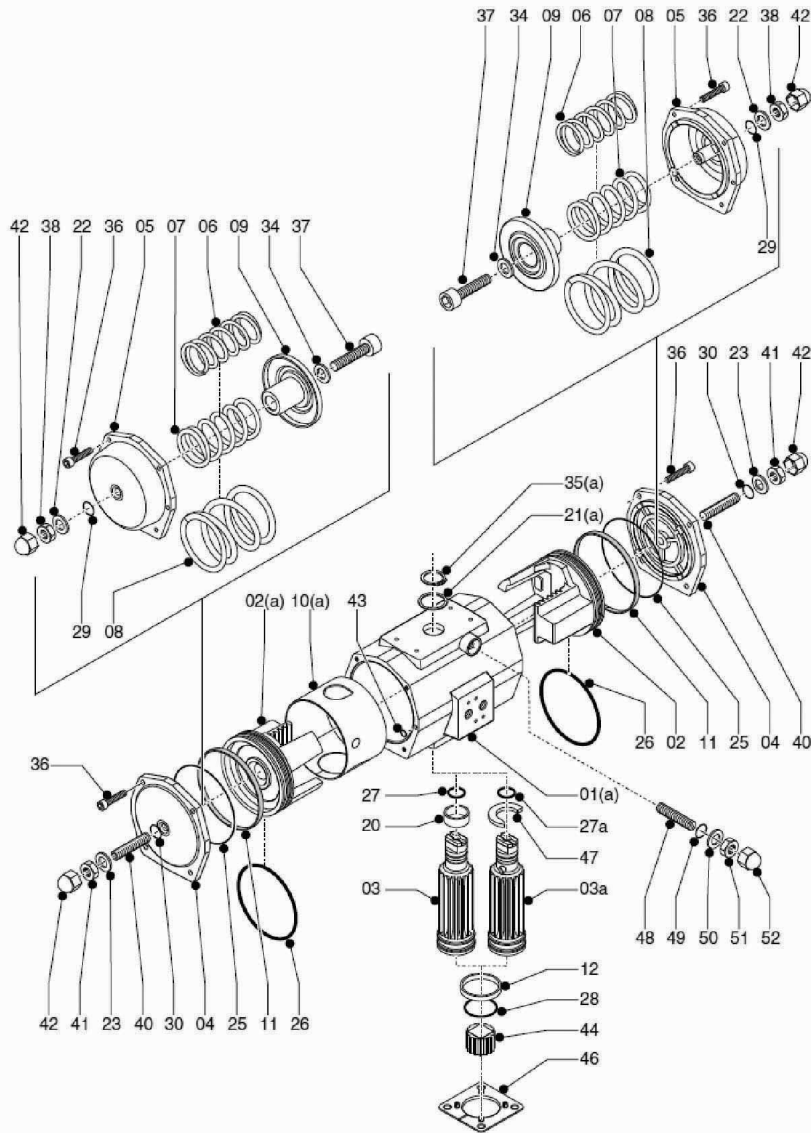

Part	Qty	
01	Body	1
02	Piston	2
03	Pinion	1
04	AD End Cap (Double Acting)	2
05	AS End Cap (Spring Return)	2
06	Inner Spring	0 to 2
07	Middle Spring	0 to 2
08	Outer Spring	0 to 2
09	Spring Holder	2
10*	Guide Band	1
11*	Piston Guide	2
12	Lower Bearing	1
20*	Upper Bearing	1

Part	Qty	
21*	Thrust Washer	1
22*	Stop Screw Washer	2
23*	Stop Screw Washer	2
25*	End Cap O-ring	2
26*	Piston O-ring	2
27*	Upper Pinion O-ring	1
28*	Lower Pinion O-ring	1
29*	Stop Screw O-ring	2
30*	Stop Screw O-ring	2
34	Stop Screw Washer	2
35	Spring Clip	1
36	End Cap Bolt	8
37	Limit Stop Bolt	2

Part	Qty	
38	Stop Adjustment Nut	2
40	Limit Stop Bolt	2
42	Nut Cover	2
43	Port O-ring	2
44	Insert/Adapter	1
47	Stroke Cam	1
48	Dual Stop Bolt	1
49*	Dual Stop O-ring	1
50*	Dual Stop Washer	1
51	Dual Stop Lock Nut	1
52	Dual Stop Nut Cover	1

* Included in Repair Kit

AD & AS ACTUATORS

Parts List – Sizes 2500 to 4000

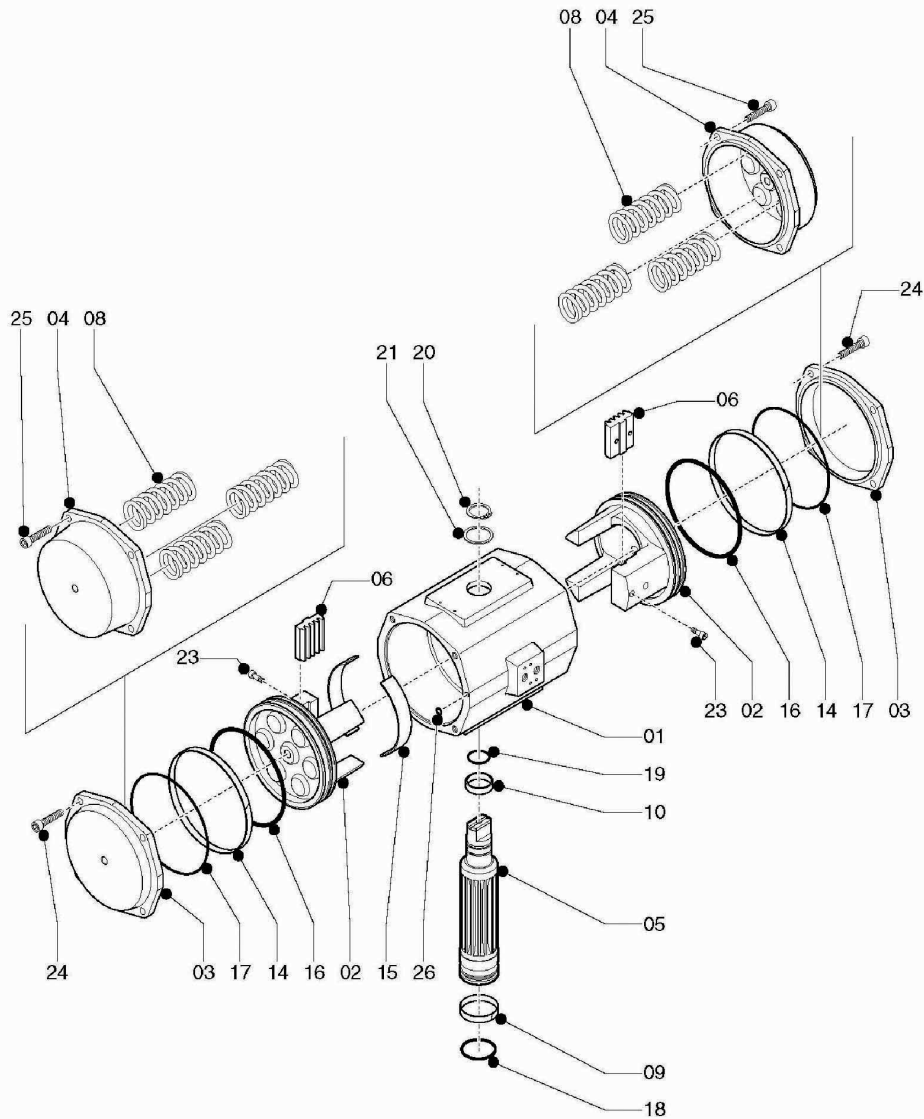

Part	Qty	
01	Body	1
02	Piston	2
03	AD End Cap (Double Acting)	2
04	AS End Cap (Spring Return)	2
05	Pinion	1
06	Gear Rack	2
08	Coil Spring	0 to 14
09*	Lower Bearing	1

Part	Qty	
10*	Upper Bearing	1
14*	Piston Guide	2
15*	Heel Guide	2
16*	Piston O-ring	2
17*	End Cap O-ring	2
18*	Lower Pinion O-ring	1
19*	Upper Pinion O-ring	1
20*	Spring Clip	1

Part	Qty	
21*	Thrust Washer	1
23	Rack Capscrew	2 or 4
24	DA End Cap Bolt	8 or 20
25	SR End Cap Bolt	8 or 20
26	Port O-ring	2

* Included in Repair Kit

AD & AS ACTUATORS

Dimensional Data – Sizes 0600 to 4000

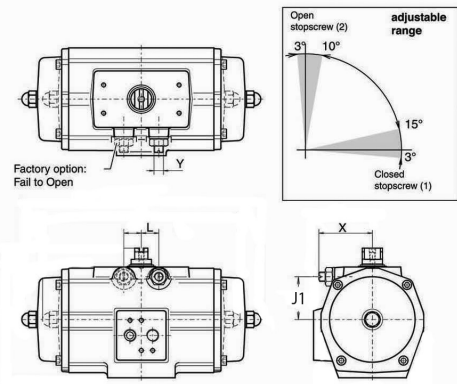
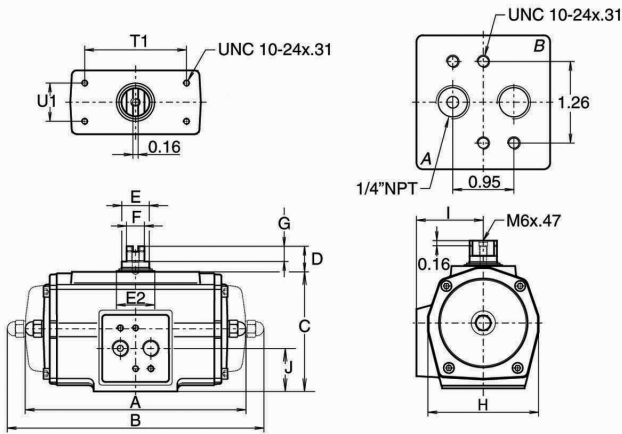

For Models with Dual Adjustable Limit Stops

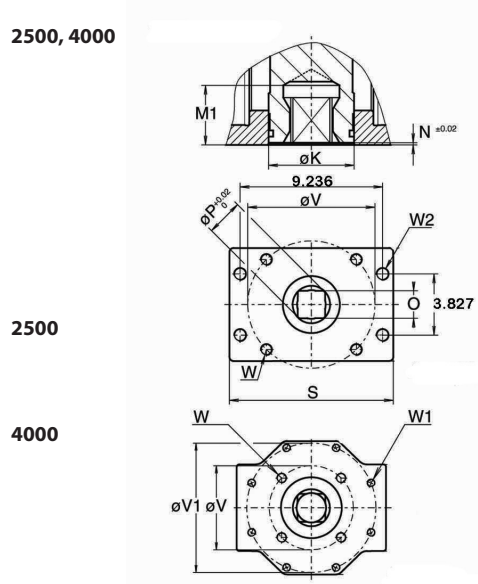
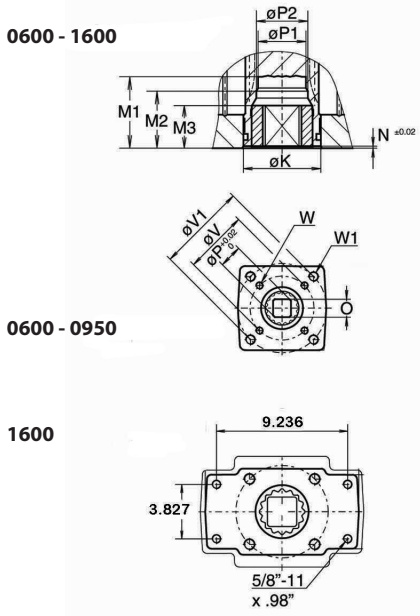

RACK & PINION ACTUATOR ENVELOPE DIMENSIONS – INCHES

Model	Overall Length A (DA)	Overall Length B (SR)	Body Height C	Body Width H	Solenoid Pad Offset I	Port Location J	Adjustable Closed Stop J1*	Adjustable Closed Stop L*	Stop Size Y*	Stop Protrusion X max.*
0600	15.24	18.78	8.66	8.15	4.45	3.33	3.50	1.63	5/8"-11	4.51
0950	16.69	20.35	10.20	9.09	4.96	4.15	4.03	1.63	5/8"-11	4.51
1600	20.31	25.08	11.69	10.43	5.59	4.74	4.50	1.87	3/4"-10	4.88
2500	14.88	22.40	14.02	13.78	7.28	7.01	N/A	N/A	N/A	N/A
4000	19.76	32.83	14.96	14.96	7.87	7.48	N/A	N/A	N/A	N/A

*Applies to double stop versions only

AD & AS ACTUATORS

Dimensional Data – Sizes 0600 to 4000

RACK & PINION ACTUATOR DRIVE DETAILS – INCHES

Model	Bottom Pinion Diameter K	Valve Stem Clearance M1	Insert or Adapter Height M3	Pinion Recess N	Standard Square Output O max	Standard Square Output O min	Across Corners Diameter P1
0600	2.68	2.05	1.16	0.06	1.068	1.063	1.425
0950	2.95	2.52	1.95	0.06	1.424	1.417	1.898
1600	3.74	3.23	2.30	0.06	1.817	1.811	2.370
2500	3.35	2.60	N/A	0.12	1.817	1.811	2.370
4000	4.72	3.03	N/A	0.06	2.173	2.165	2.843

RACK & PINION ACTUATOR MOUNTING DIMENSIONS – INCHES

Model	Primary ISO "F" Pattern	Primary Bolt Circle V	Primary Fastener W	Secondary ISO "F" Pattern	Secondary Bolt Circle V1	Secondary Fastener W1
0600	F10	4.016	3/8"-16 x .63"	F12	4.921	1/2"-13 x .79"
0950	F10	4.016	3/8"-16 x .63"	F14	5.512	5/8"-11 x .98"
1600	F16	6.496	3/4"-10 x 1.14"	N/A	N/A	N/A
2500	F16	6.496	3/4"-10 x 1.14"	N/A	N/A	N/A
4000	F16	6.496	3/4"-10 x 1.14"	F25	10.000	5/8"-11 x .98"

RACK & PINION ACTUATOR MOUNTING DETAILS – INCHES

Model	Namur Shaft Extension D	Namur Shaft Diameter E	Thrust Bearing Diameter E2	Namur Shaft Flats F	Namur Flat Length G	Namur Bolt Pattern T1	Namur Bolt Pattern U1
0600	1.18	2.17	2.56	1.42	0.39	5.118	1.181
0950	1.18	2.17	2.56	1.42	0.39	5.118	1.181
1600	1.18	2.52	2.95	1.42	0.39	5.118	1.181
2500	1.18	2.17	2.56	1.42	0.39	5.118	1.181
4000	1.18	2.52	3.15	1.42	0.39	5.118	1.181

AD & AS ACTUATORS

Torque Output

TORQUE OUTPUT OF DOUBLE ACTING RACK & PINION ACTUATORS (IN - LB)

Actuator Size	Supply Pressure (psi)										
	40	45	50	55	60	70	75	80	90	100	120
AD0600	2986	3366	3747	4127	4507	5267	5647	6028	6788	7548	9069
AD0950	4458	5025	5593	6160	6728	7862	8430	8997	10132	11267	13537
AD1600	7369	8307	9245	10183	11121	12998	13936	14874	16750	18626	22379
AD2500	11825	13270	14768	16267	17847	20858	22363	23869	26880	29891	35912
AD4000	19962	22495	25035	27576	30127	35210	37751	40293	45375	50458	60623

TORQUE OUTPUT OF SPRING RETURN RACK & PINION ACTUATORS (IN - LB)

Actuator Size	Spring Set	Spring Stroke		Air Stroke Supply Pressure (psi)									
				40		60		80		100		120	
		Start	End	Start	End	Start	End	Start	End	Start	End	Start	End
AS0600	2	1723	1082	1920	1183	3531	2794	5142	4405	6753	6016	8364	7628
	3	2585	1624	1298	193	2909	1804	4520	3415	6131	5026	7742	6637
	4	3446	2165	-	-	2287	814	3898	2425	5509	4036	7120	5647
	5	4308	2706	-	-	-	-	3276	1434	4887	3046	6498	4657
	6	5169	3247	-	-	-	-	2654	444	4265	2055	5876	3666
AS0950	2	2563	1587	2898	1777	5303	4182	7708	6587	10113	8992	12518	11397
	3	3844	2381	1986	304	4391	2709	6796	5114	9201	7519	11606	9924
	4	5125	3175	-	-	3479	1236	5884	3641	8288	6046	10693	8451
	5	6407	3968	-	-	-	-	4971	2168	7376	4573	9781	6978
	6	7688	4762	-	-	-	-	4059	695	6464	3100	8869	5505
AS1600	2	4193	2646	4765	2988	8741	6964	12716	10939	16692	14915	20668	18890
	3	6289	3970	3244	578	7220	4554	11196	8530	15171	12505	19147	16481
	4	8385	5293	-	-	5699	2145	9675	6120	13650	10096	17626	14071
	5	10481	6616	-	-	-	-	8154	3711	12129	7686	16105	11662
	6	12578	7939	-	-	-	-	6633	1301	10608	5277	14584	9252
AS2500	6	7013	4401	6881	4278	12875	10273	18869	16267	24863	22261	30858	28255
	8	9351	5868	5251	1781	11245	7775	17239	13769	23233	19764	29228	25758
	10	11689	7335	-	-	9615	5278	15609	11272	21603	17266	27597	23260
	12	14026	8803	-	-	7985	2780	13979	8774	19973	14768	25967	20763
	14	16364	10270	-	-	-	-	12349	6277	18343	12271	24337	18265
AS4000	6	11835	7429	11701	7310	21862	17472	32024	27633	42185	37795	52347	47956
	8	15780	9905	8949	3096	19111	13257	29272	23419	39434	33580	49595	43742
	10	19725	12381	-	-	16359	9042	26521	19204	36682	29365	46844	39527
	12	23670	14857	-	-	13608	4828	23770	14989	33931	25150	44093	35312
	14	27615	17333	-	-	-	-	21018	10774	31180	20936	41341	31097

▶STANDARD

AD & AS ACTUATORS

Technical Data – Sizes 0600 to 4000

Double Acting	AD0600	AD0950	AD1600	AD2500	AD4000
Weight (lbs)	43	58	95	125	191

Spring Return	AS0600	AS0950	AS1600	AS2500	AS4000
Weight (lbs)	61	85	145	194	291

Displacement	(cu in.)	AD0600	AD0950	AD1600	AD2500	AD4000
		AS0600	AS0950	AS1600	AS2500	AS4000
Port A	CCW	177	287	445	488	824
Port B	CW	189	299	488	568	1068

Air consumption (scf per 90°) = (Displacement/1728)(Supply Pressure + 14.7)/14.7*

Operating Time	AD0600 AS0600	AD0950 AS0950	AD1600 AS1600	AD2500 AS2500	AD4000 AS4000
Seconds	4.5	5.4	6.9	7	12

SELECTING/SIZING APOLLO RACK & PINION ACTUATORS

Establish the valve operating torque beginning with the torque constants for the appropriate pressure and valve as found on pages 49-51. Use the torque adjustment factors found on page 52 to arrive at an in-service torque. Multiple adjustment factors may be required. Do not forget to include adjustments for graphite stem packing.

FOR DOUBLE ACTING ACTUATORS

Based on the available air supply select an actuator with torque outputs that exceed the in-service torque by at least 10%.

FOR SPRING RETURN ACTUATORS

Considering the available air supply, select an actuator where both the Spring-Ending torque figure and the Air-Ending torque figure exceeds the in-service torque by at least 10%.

Note: Single-Stop actuators are appropriate for use on ball valves. Dual-Stop actuators are required for most butterfly valve applications but may also be used on ball valves.

How to Order Apollo Pneumatic Rack & Pinion Actuators – AD and AS (Sizes 0600 to 4000)

APOLLO RACK & PINION NUMBERING SYSTEM

A	S	1600	N	04	1	A	F
PREFIX	ACTION	SIZE	SEAL OPTION	SPRING SET	LIMIT STOP	INSERTS	"AS" MODEL ONLY
A	D = DOUBLE ACTING S = SPRING RETURN K = KIT	0600 0950 1600 2500* 4000*	N = NITRILE (Normal temp range, -4° to 175°F) H = FLOUROCARBON (High temp range, -4° to 250°F) L = SILICONE (Low temp range, -40° to 175°F)	00 (DA) 01 02 03 04 05 06 07 08 10 12 14	0 = None** (Std. on sizes 0012, 2500, & 4000) 1 = Single Adjustable Limit Stop (For sizes 0025 thru 1600 only) 2 = Dual Adjustable Limit Stops (For sizes 0025 thru 1600 only)	A = STANDARD SQUARE B = WITHOUT	Add Suffix "F" if spring-to-open (i.e. fail open), otherwise, leave blank

* No insert adapter options

** Optional double stroke adjustment plate is available for 2500 & 4000 (see price list)

AD & AS ACTUATORS

Acuator Inserts – Sizes 0025 to 1600

Actuator	Item Number	Description	Fits Stems of the Following Dimensions			
			Imperial (in)		Metric (mm)	
			X-Dimension	Y-Dimension	X-Dimension	Y-Dimension
AD/AS 0025	CX04573	ADAPTER, 11MM SQ	0.433	0.433	11	11
	CX04549	ADAPTER,0.500DIA X 0.397FLAT,	0.394	Ø0.500	10	Ø13
	CX04684	ADAPTER,BLANK				
AD/AS 0040/0065	CX04620	ADAPTER, 77D104 TO AD/AS 0040,0065; 7MM SQ.	0.28	0.28	7	7
	CX04550	ADAPTER,0.555DIA X 0.397FLAT,	0.394	Ø0.55	10	Ø14
	CX04570	ADAPTER,11MM SQ,ALUM,77D105 TO	0.433	0.433	11	11
	CX04551	ADAPTER,0.625DIA X 0.476FLAT,	0.476	Ø0.627	12	Ø16
	CX04580	ADAPTER,14MM SQ,	0.551	0.55	14	14
	CX04552	ADAPTER,0.751DIA X 0.555FLAT,	0.551	Ø0.748	14	Ø19
	CX04675	ADAPTER,BLANK				
AD/AS 0100	CX04553	ADAPTER,0.397DIA X 0.524FLAT,	0.394	0.524	10	Ø13
	CX04554	ADAPTER,0.625DIA X 0.475FLAT,	0.476	Ø0.627	12	Ø16
	CX04623	ADAPTER, 14MM SQ	0.551	0.55	14	14
	CX04555	ADAPTER,0.750DIA X 0.555FLAT,	0.551	Ø0.748	14	Ø19
	CX04584	ADAPTER, 17MM SQ	0.669	0.669	17	17
	CX04569	ADAPTER,19MM (0.748 SQ,)	0.748	0.748	19	19
	CX04685	ADAPTER,BLANK				
AD/AS 0150/0200/0350/0600	CX04556	ADAPTER,0.628DIA X 0.376FLAT,	0.375	Ø.628	9.5	Ø16
	CX04720	ADAPTER, 11MM SQ	0.433	0.433	11	11
	CX04558	ADAPTER,0.475DIA X 0.650RECT,	0.475	0.65	12	17
	CX04572	ADAPTER, 77D107-108 TO	0.551	0.551	14	14
	CX04566	ADAPTER,0.750DIA X 0.555FLAT,	0.551	Ø0.748	14	Ø19
	CX04560	ADAPTER,0.673 X 0.886RECT,	0.669	0.875	17	22
	CX04571	ADAPTER,19MM	0.748	0.748	19	19
	CX04581	ADAPTER,22MM	0.87	0.87	22	22
	CX04559	ADAPTER,0.869DIA X 1.18RECT,	0.87	1.18	22	30
	CX04557	ADAPTER,1.250DIA X 0.949FLAT,	0.95	Ø1.25	24	Ø32
	CX04582	ADAPTER,27MM	1.063	1.063	27	27
	CX04686	ADAPTER,BLANK				
	AD/AS 0950	CX04567	ADAPTER,0.673 X 0.886RECT,	0.669	0.886	17
CX04562		ADAPTER,1.125DIA X 0.870FLAT,	0.87	Ø1.127	22	Ø29
CX04561		ADAPTER,1.250DIA X 0.949FLAT,	0.95	Ø1.25	24	Ø32
CX04622		ADAPTER, 36MM SQ	1.417	1.417	36	36
CX04563		ADAPTER,BLANK				
AD/AS 1600	CX04568	ADAPTER,1.250DIA X 0.870FLAT,	0.87	Ø1.127	22	Ø29
	CX04564	ADAPTER,1.248DIA X 0.950FLAT,	0.95	Ø1.25	24	Ø32
	CX04565	ADAPTER,BLANK				

AD/AS 0150/0200/0350/0600 (Fits HPBFVs)	CX04680	CLASS 150/300 2"HPBFV (.356 x .490)	0.354	0.49	9	12.5
	CX04714	CLASS 150/300 2-1/2" & 3" HPBFV (.434 x .580)	0.433	0.55	11	14
	CX04681	CLASS 150/300 4"HPBFV (.553 x .725)	0.551	0.725	14	18
	CX04682	CLASS 150/300 5"&6" HPBFV (.671 x .890)	0.669	0.886	17	22.5
	CX04683	CLASS 150 8" HPBFV (.750 x 1.01)	0.748	1.01	19	25.5

Notes:

1. Inserts for optional stem sizes or when the actuator is ordered without a factory installed insert.
2. Contact factory for additional configurations and pricing.

Insert-Stem Dimensions

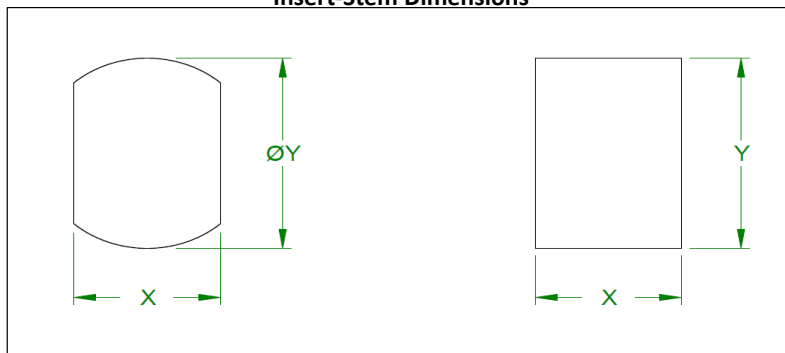

ACUTORQUE STAINLESS STEEL ACTUATOR

Design and Construction

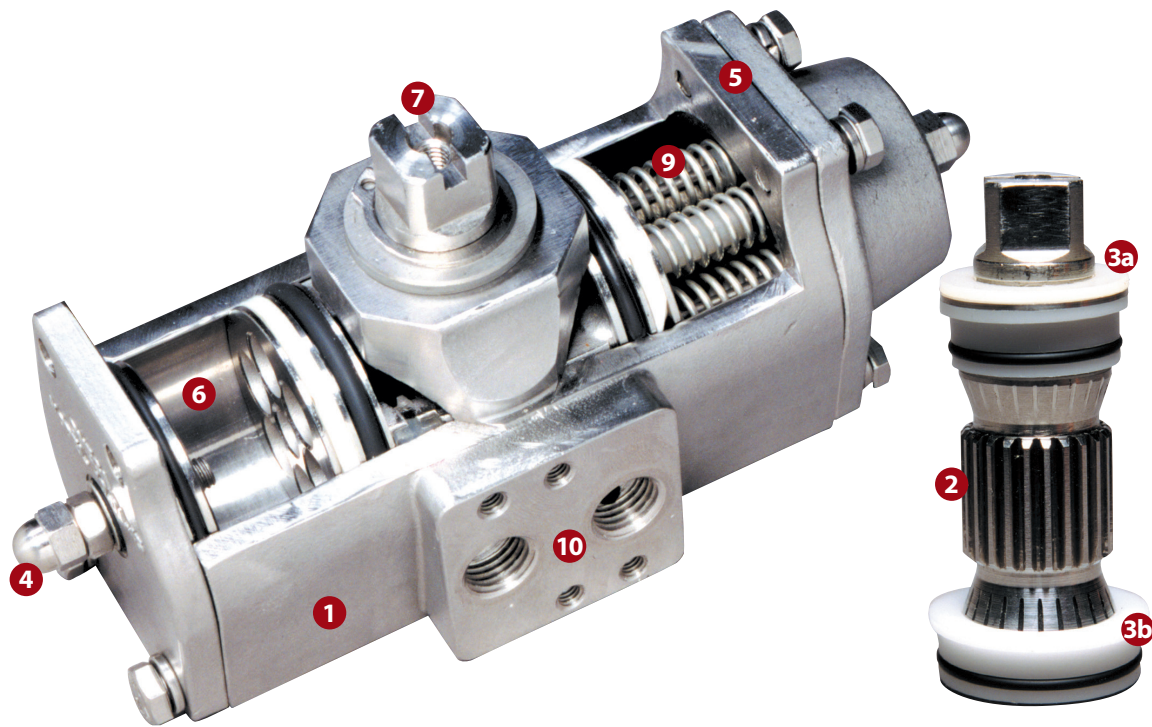

1. INVESTMENT CAST BODY

Assures manufacturing of other special alloys, such as Monel

2. UNIQUE DRIVE PINION

One piece stainless steel alloy shaft, precision machined gear and teeth for precise control

3. BEARINGS

Replaceable top and bottom TFE Pinion Bearings to ensure low friction, stability above 400°F, and chemical resistance

4. TRAVEL STOPS

Provides +/-4° travel adjustment in outboard direction

5. ACCESSORY MOUNTING

Manufactured to NAMUR to provide international standardized mounting

6. STAINLESS STEEL PISTONS

Precision cast pistons are guided through full face engagement with the pinion and piston guide

7. NAMUR SLOTTED SHAFT

Standard to provide a self-centering positive drive for positioners, a variety of switches

8. ACTUATOR MOUNTING

Manufactured in accordance with ISO 5211 to ensure mounting the actuator directly on valves

9. PRE-LOADED CARTRIDGES

Converts a standard double acting actuator to a spring return unit by simply removing the end caps and adding the spring cartridges

10. NAMUR SOLENOID MOUNTING

International standard for direct mounting of solenoid valves

ACUTORQUE STAINLESS STEEL ACTUATOR

Operation

The Apollo® Acutorque actuator is manufactured with an integral and internal air manifold. The solenoid mounting pad is manufactured to Namur dimensional standards as to allow for the direct mounting of various manufacturers' solenoid valves and other flow control devices. For applications not requiring a direct mount solenoid valve, ports are tapped to NPT standards (American National Standard taper threads).

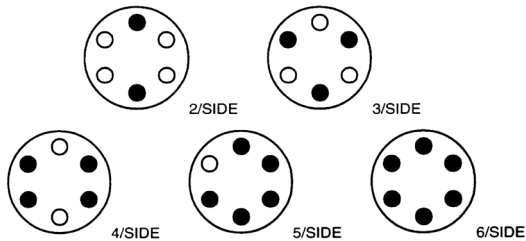

REVERSE ROTATION

When required, a clockwise rotation of the drive pinion, by means of air to PORT A can be achieved by reversing the pistons inside the actuator body (rotate 180 degrees).

SPRING CONFIGURATION

Each Acutorque actuator comes with a complete spring pack (6 springs per side with nylon retainers) unless otherwise specified. When less than the full spring pack is desired for various torque outputs (see torque chart); springs can be removed from the actuator end caps. It is very important that springs can be arranged in a symmetrical manner (positioned as shown) so that unwarranted side-load does not occur between the pistons and actuator body. *CAUTION: Refer to operation and maintenance instructions before disassembly and removal of springs.*

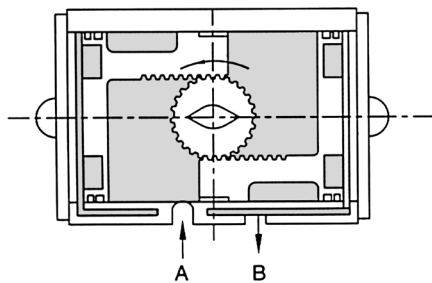

Air to PORT A: Pressure applied enters center of chamber forcing the pistons outward and rotating the drive pinion in a counter-clockwise direction and forcing exhaust air out of PORT B.

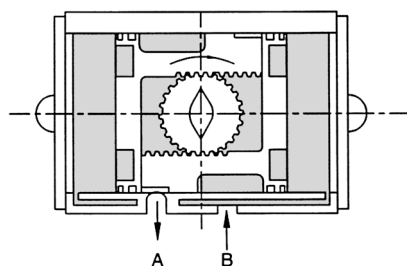

Air to PORT B: Air pressure enters the outer chambers forcing the pistons inward and rotating the drive pinion in a clockwise direction while forcing exhaust air out of PORT A.

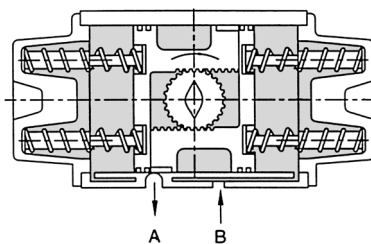

Loss of air pressure in the center chamber allows energy in the compressed springs to force the pistons inward, resulting in a clockwise rotation of the drive pinion while exhaust air leaves via PORT A.

ACUTORQUE STAINLESS STEEL ACTUATOR

Features

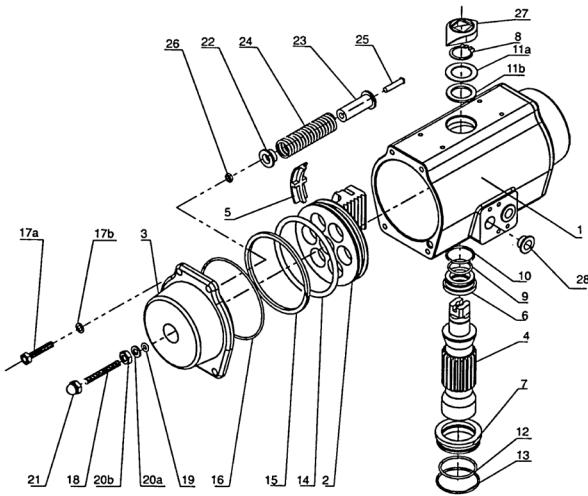

CORROSION RESISTANCE

All metal components are cast or machined from Stainless Steel or Monel, which offers excellent resistance to most corrosive chemicals as well as industrial atmospheres.

NO LUBRICATION

All actuators are factory lubricated for the optimum life of the actuator under normal conditions. Teflon® piston bearings are used because of their self-lubricating properties.

SIMPLE MAINTENANCE

Each actuator is designed for ease of maintenance. Should you wish to change a spring rating or completely rebuild a unit, total disassembly and reassembly is easily performed in just minutes with standard shop tools.

ISO/NAMUR MOUNTING

By using ISO/Namur standards, our actuators lend themselves to a host of various manufacturers' direct mount accessories. Solenoid valves, limit switches, positioners, etc. bolt directly to the actuator and in turn reduces the cost of assembly and installation of automated packages. Flexibility for future system modifications is greatly enhanced.

QUALITY

Each part of the actuator must pass a stringent quality test before it can be incorporated into an assembly. All materials used in construction must be certified and tested to prove their proper composition. Every cast part must pass an X-ray test before proceeding to the machining process. After machining, every part is dimensionally evaluated to assure it meets acceptable tolerance.

SAFETY

All actuator bodies and end caps are investment cast stainless steel, rugged and built to last. It may be argued that the mechanical properties of stainless steel permit the ability to use this wall tubing in the construction of an actuator. However, that is not the case with our actuator. Thick wall castings mean protection for actuator internal porting and components as well as maintenance and operating personnel. Our unique drive pinion design ensures blowout proof protection. Spring retainers are incorporated to allow safe removal of end caps during spring torque rating change or rebuild process.

GRADE OF STAINLESS STEEL

Body & End Caps	304
Shaft	17-4 ph
Piston	303
Bolts	18-8

Part	Qty	Material
1 Body	1	304 Stainless Steel
2 Piston	2	303 Stainless Steel
3 End Caps-Double Acting	2	Stainless Steel
4 Drive Pinion	1	17-4 Stainless Steel
5 Guide Bearing Plate	2	Nylon 6
6 Pinion Bearing Top	1	Teflon
7 Pinion Bearing Bottom	1	Teflon
8 Snap Ring	1	Stainless Steel
9 O-Ring-Inner Top	1	Viton
10 O-Ring-Outer Top	1	Viton
11a Washer	1	Stainless Steel
11b Bearing	1	Nylon 6
12 O-Ring-Inner Bottom	1	Viton
13 O-Ringer-Outer Bottom	1	Viton
14 O-Ring-Piston	2	Viton
15 Bearing-Piston	2	Nylon 6

Part	Qty	Material
16 O-Ring-End Cap	2	Nitrile
17a Bolts-End Cap	8	Stainless Steel
17b Spring Bearing	8	Stainless Steel
18 Adjusting Travel Stop	2	Stainless Steel
19 O-Ring-Travel Stop	2	Nitrile
20a Washer	2	Stainless Steel
20b Nut-Travel Stop	2	Stainless Steel
21 End Nut-Travel	2	Stainless Steel
22 Spring Retainer (S)	*	Nylon 6
23 Spring Retainer (L)	*	Nylon 6
24 Spring	*	Plated CS
25 Spring Screw	*	Stainless Steel
26 Spring Nut	*	Stainless Steel
27 Positioner Indicator	1	Nylon
28 Plug	2	Nylon 6

ACUTORQUE STAINLESS STEEL ACTUATOR

Dimensional Data

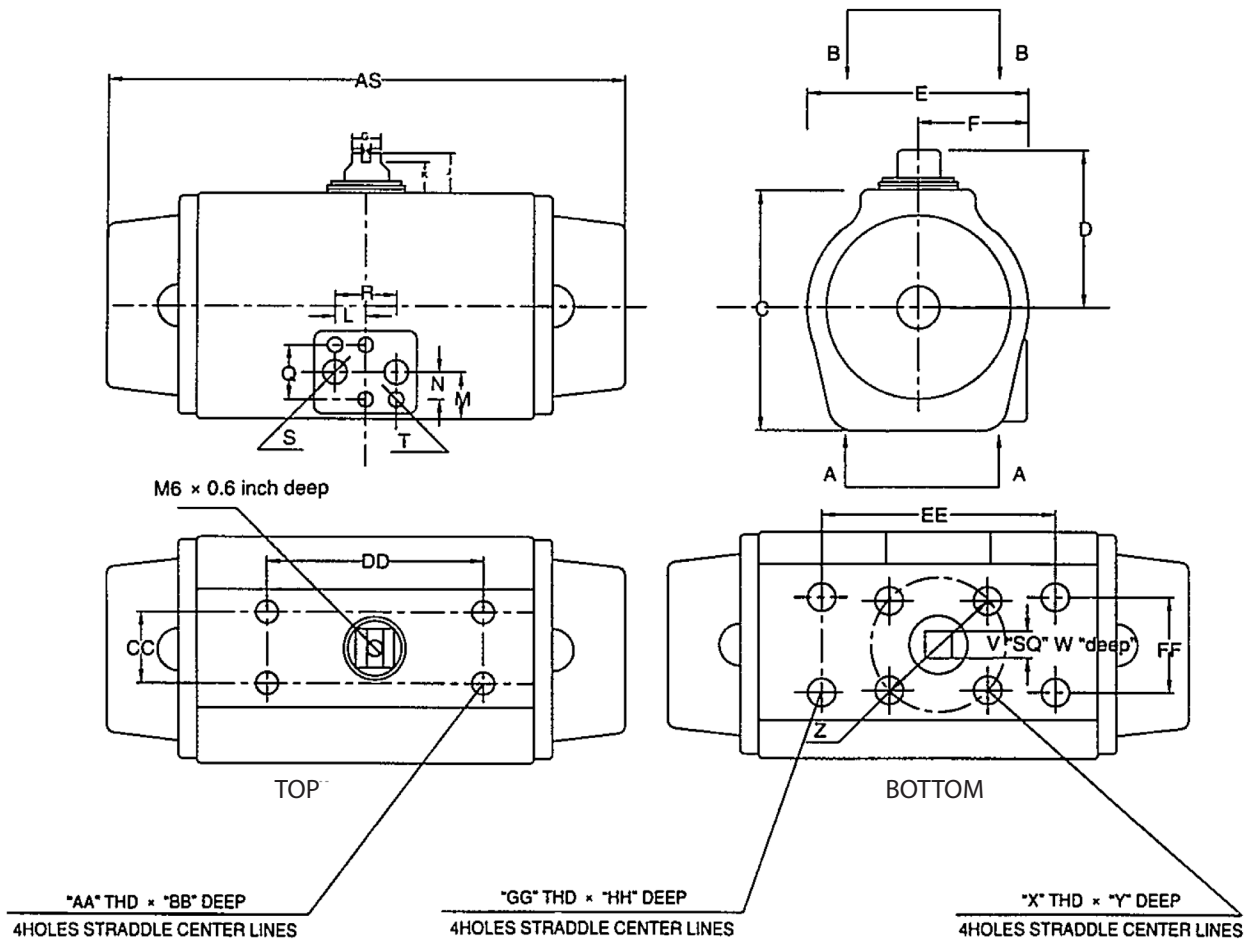

MOUNTING DIMENSIONS

Model		R	S	T	V	W	X	Y	Z	AA	BB	CC	DD	EE	FF	GG	HH
3SD04500	mm	24	1/4"NPT	M5	11	15	M5	8	42	M5	6	30	80	88.9	31.75	M5	8
3SS04560	in	0.95	1/4"NPT	M5	0.4	0.59	M5	0.31	1.65	M5	0.24	1.18	3.15	3.5	1.25	M5	0.31
3SD06000	mm	24	1/4"NPT	M5	14	15	M6	8	50	M5	6	30	80	88.9	31.75	M6	8
3SS06060	in	0.95	1/4"NPT	M5	0.55	0.59	M6	0.31	1.97	M5	0.24	1.18	3.15	3.5	1.25	M6	0.31
3SD08500	mm	24	1/4"NPT	M5	19	17	M8	12	70	M5	6	30	80	114	38	M8	12
3SS08560	in	0.95	1/4"NPT	M5	0.75	0.68	M8	0.47	2.75	M5	0.24	1.18	3.15	4.5	1.5	M8	0.47
3SD10500	mm	24	1/4"NPT	M5	19	20	M8	12	70	M5	6	30	80	114	38	M8	12
3SS10560	in	0.95	1/4"NPT	M5	0.75	0.79	M8	0.47	2.75	M5	0.24	1.18	3.15	4.5	1.5	M8	0.47
3SD12500	mm	24	1/4"NPT	M5	22	30	M8	18	102	M5	8	30	130	NA	50.8	NA	NA
3SS12560	in	0.95	1/4"NPT	M5	0.87	1.2	M8	0.71	4.02	M5	0.31	1.18	5.12	NA	2	NA	NA
3SD14000	mm	24	1/4"NPT	M5	22	27	M10	18	102	M5	8	30	130	NA	50.8	NA	NA
3SS14060	in	0.95	1/4"NPT	M5	0.87	1.06	M10	0.71	4.02	M5	0.31	1.18	5.12	NA	2	NA	NA
3SD17000	mm	24	1/4"NPT	M5	32	36	M12	24	125	M5	8	30	130	NA	76	NA	NA
3SS17060	in	0.95	1/4"NPT	M5	1.26	1.42	M12	0.95	4.92	M5	0.31	1.18	5.12	NA	3	NA	NA
3SD21000	mm	24	1/4"NPT	M5	36	43	M20	28	140	M5	8	30	130	NA	76	NA	NA
3SS21060	in	0.95	1/4"NPT	M5	1.42	1.69	M20	1.1	5.51	M5	0.31	1.18	5.12	NA	3	NA	NA

ACUTORQUE STAINLESS STEEL ACTUATOR

Envelope Dimensions

DIMENSIONS

Model		AS	C	D	E	F	G	H	J	K	L	N	M	Q
3SD04500	mm	168	65	52.5	62.5	35	16	4	20	10	12	16	23	32
3SS04560	in	6.61	2.56	2.07	2.46	1.38	0.63	0.16	0.79	0.39	0.47	0.63	0.91	1.26
3SD06000	mm	180	81	60.5	74	39	16	4	20	10	12	16	23	32
3SS06060	in	7.09	3.19	2.38	2.91	1.54	0.63	0.16	0.79	0.39	0.47	0.63	0.91	1.26
3SD08500	mm	222	108	74	100.5	52	16	4	20	10	12	16	24	32
3SS08560	in	8.74	4.25	2.91	3.96	2.05	0.63	0.16	0.79	0.39	0.47	0.63	0.95	1.26
3SD10500	mm	290	133	86.5	117	58.5	16	4	20	10	12	16	30	32
3SS10560	in	11.42	5.24	3.41	4.61	2.3	0.63	0.16	0.79	0.39	0.47	0.63	1.18	1.26
3SD12500	mm	390	155	110.2	136	68	20	4	30.5	10.5	12	16	40	32
3SS12560	in	15.5	5.02	3.59	5.65	2.91	0.79	0.16	1.2	0.41	0.47	0.63	1.57	1.26
3SD14000	mm	420	176	116.5	156	79	20	4	30.5	10.5	12	16	40	32
3SS14060	in	16.54	6.93	4.59	6.14	3.11	0.79	0.16	1.2	0.41	0.47	0.63	1.57	1.26
3SD17000	mm	538	210	131.5	193	98	20	4	30.5	10.5	12	16	50	32
3SS17060	in	21.18	8.27	5.18	7.6	3.86	0.79	0.16	1.2	0.41	0.47	0.63	1.97	1.26
3SD21000	mm	698	258	156	236	120	32	4	30.5	10.5	12	16	68	32
3SS21060	in	27.48	10.16	6.14	9.29	4.72	1.26	0.16	1.2	0.41	0.47	0.63	2.68	1.26

Technical Data – “Acutorque” Stainless Steel Actuator

Acuator Model	Volume (in ³ per 90° cycle)	Air Consumption (scf per 90° rotation)*	
		CW	CCW
3SS045X0	45	8.5	6.5
3SS060X0	60	17.5	14.8
3SS085X0	85	36.5	24.5
3SS105X0	105	72	49.3
3SS125X0	125	196	147
3SS140X0	140	358	278
3SS170X0	170	542	382
3SS210X0	210	753	470

Acuator Model	Weight (lbs)
3SS045X0	9
3SS060X0	16
3SS085X0	23
3SS105X0	37
3SS125X0	52
3SS140X0	75
3SS170X0	188
3SS210X0	258

Notes: *Temperature and atmospheric conditions could change values above.

Double Acting Torque – Acutorque Stainless Steel Actuator

Actuator Model	Torque (Inch/Lbs) vs. Air Supply Pressure (PSI)					
	40	60	80	100	120	150
3SD04500	74	116	152	199	239	289
3SD06000	151	234	328	413	499	600
3SD08500	365	548	732	915	1097	1315
3SD10500	701	1068	1436	1829	2184	2632
Actuator Model	Torque (Inch/Lbs) vs. Air Supply Pressure (PSI)					
	40	60	80	100	120	150
3SD12500	1355	2069	2759	3449	4115	5168
3SD14000	2018	3032	4039	5046	6056	6615
3SD17000	2868	4050	5324	6640	7987	10042
3SD21000	5328	8462	11188	13884	16709	20929

ACUTORQUE STAINLESS STEEL ACTUATOR

Spring Return Torque

Actuator Model	Spring Set#*	Spring Stroke		Torque (Inch/Lbs) vs. Air Supply Pressure (PSI)											
				40		60		80		100		120		150	
		0	90	0	90	0	90	0	90	0	90	0	90	0	90
3SS045X0	2	34	21	56	43	98	84	136	121	178	162	220	203	256	230
	3	49	29	45	24	88	65	126	93	165	142	204	179	238	204
	4	71	43			72	42	115	90	154	126	196	163	218	175
	5	88	52					109	76	147	109	182	184	209	156
	6	107	64					97	58	135	91	172	103	190	129
3SS060X0	2	61	37	101	79	167	140	237	214	304	278	369	345	435	399
	3	93	55	84	48	147	107	219	185	284	248	352	315	405	350
	4	124	75			129	77	203	157	268	219	331	276	380	315
	5	156	93			110	45	187	131	250	189	315	250	359	272
	6	186	112					171	102	233	158	296	218	335	228
3SS085X0	2	172	93	275	206	450	369	645	572	821	744	999	919	1175	1065
	3	257	139	236	126	403	281	602	493	773	661	949	884	1105	945
	4	343	185			354	192	558	414	729	574	901	743	1042	825
	5	428	232					516	303	683	490	853	651	975	705
	6	515	288					473	258	636	405	800	564	915	580
3SS105X0	2	325	182	527	394	852	703								
	3	483	256	443	246	759	537	1137	939						
	4	643	358			665	369	1051	790	1374	1099	1703	1413	1975	1570
	5	805	447			556	119	974	641	1291	934	1615	1241	1852	1340
	6	964	537					888	493	1195	777	1519	1077	1705	1100
3SS125X0	2	628	343	1025	730	1724	1435								
	3	945	510	860	425	1545	1118	2310	1864						
	4	1259	687			1370	806	2068	1480	2720	2158	3333	2450	4166	3062
	5	1579	865			1199	483	1875	1160	2545	1835	3157	2185	3947	2728
	6	1895	1040					1690	850	2371	1528	2915	1846	3628	2310
3SS140X0	2	905	520	1478	1092	2469	2088								
	3	1355	780	1215	642	2210	1639	3195	2620						
	4	1808	1035			1956	1197	2935	2180	3960	3175	5000	4000	6250	5010
	5	2257	1301			1692	739	2680	1750	3700	2748	4608	3425	5760	4290
	6	2708	1562					2441	1279	3444	2290	4280	2852	5362	3568
3SS170X0	2	1227	738	1985	1494	3411	2923								
	3	1830	1092	1824	1087	3045	2347	3945	3626						
	4	2417	1446			2695	1713	4012	3035	4307	4291	6305	5221	7890	6526
	5	3044	1811			2329	1104	3647	2417	4934	3700	6000	4608	7495	5760
	6	3653	2166					3295	1817	4579	3093	5719	3750	7149	4680
3SS210X0	2	2425	1388	4080	2988	7149	6112								
	3	3640	2080	3388	1831	6456	4899	9205	7626						
	4	4857	2769			5750	3675	8510	6438	11150	9082	9231	12900	16100	12835
	5	6060	3465			5070	2475	7772	5224	10400	5160	7835	12000	15000	11030
	6	7270	4165					7125	4010	9700	4238	6616	10909	13650	9150

* X in Actuator Model is Spring Set

SCOTCH-YOKE ACTUATORS

G Series

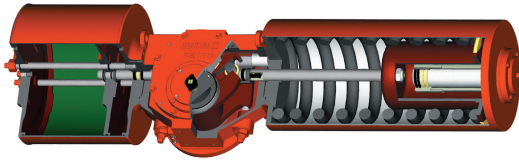

NAMUR

The shaft driven accessory interface conforms to the NAMUR standard and is identical on all G-Series actuators, allowing for standardization of accessory mounting hardware and installation practices

- Pneumatic and hydraulic scotch-yoke actuators
- Automates ball, butterfly, plug valves and any other 90° rotating mechanisms
- Salt Spray Testing per ASTM B117 criteria. Construction features prevent water ingress, allowing G-Series actuators to meet IP 66 and IP 67M specifications and severe high pressure water deluge test

OPERATING RANGES

G-Series double acting actuators produce guaranteed minimum torque outputs from 10,000 lb-in. up to 6,000,000 lb-in. The spring return units produce spring torques from 2,500 lb-in. to 3,000,000 lb-in.

- Standard operating pressures:
Pneumatic — to 200 psig (14 BAR)
- Standard operating temperature is -20°F to +200°F (-29°C to +93°C)
Optional trims available:
0°F to +350°F (-18°C to +177°C)
-50°F to +180°F (-46°C to +82°C)
- Mechanical and hydraulic manual overrides are available
- MSS and ISO Valve Mounting
The G-Series valve interface meets the dimensional requirements of MSS SP-101 or ISO 5211 defined for each torque range

DOUBLE ACTING G1 PNEUMATIC ACTUATOR TORQUE CHART

Apollo Model No.	Reference Number	Stroke Position	Operating Pressure (psig)											
			40	50	60	70	80	90	100	110	120	150	175	200
			Output Torque (In-Lbs)											
3TG100800	G01008	Start/End	12465	14543	16620	18698	20775	22853	24930	31163	36356	41550		
		Minimum			6579	7675	8772	9868	10965	12061	13158	16447	19188	21929
3TG100900	G01009	Start/End	10593	13241	15890	18538	21186	23835	26483	29131	31779	39724		
		Minimum	5591	6989	8386	9784	11182	12579	13977	15375	16772	20966		
3TG101000	G01010	Start/End	14046	17557	21069	24580	28092	31603	35115	38626				
		Minimum	7413	9266	11120	1973	14826	16680	18533	20386				
3TG101200	G01012	Start/End	20133	25166	30199	35232								
		Minimum	10626	13282	15938	18595								
3TG101400	G01014	Start/End	24482	30603	36723									
		Minimum	12921	16152	19382									

SCOTCH-YOKE ACTUATORS

Torque Ratings G Series

All published torques are guaranteed minimum values.

G SERIES PNEUMATIC DOUBLE-ACTING ACTUATOR TORQUE CHART

Apollo Model No.	Reference Number	Stroke Position	Operating Pressure (psig)											
			40	50	60	70	80	90	100	110	120	150	175	200
			Output Torque (In-Lbs)											
3TG200900	G2009	Start/End				22441	25647	28852	32058	35264	38470	48087	56102	
		Minimum			11844	13536	15228	16920	18612	20304	25379	29609		
3TG201000	G2010	Start/End		21254	25504	29755	34006	38257	42507	46758	51009			
		Minimum		11217	13461	15704	17948	20191	22434	24678	26921			
3TG201200	G2012	Start/End	24371	30464	36556	42649	48742	54835	60927					
		Minimum	12862	16078	19294	22509	25725	28941	32156					
3TG201400	G2014	Start/End	29636	37046	44455	51864	59273							
		Minimum	15641	19552	23462	27373	31283							
3TG201600	G2016	Start/End	39118	48897	58677									
		Minimum	20646	25807	30968									
3TG301000	G3010	Start/End				35888	41015	46142	51269	56396	61523	76903	89721	102538
		Minimum				18941	21647	24353	27059	29764	32470	40588	47352	54117
3TG301200	G3012	Start/End		36847	44216	51585	58955	66324	73693	81063	88432			
		Minimum		19447	23336	27226	31115	35004	38894	42783	46672			
3TG301400	G3014	Start/End	35887	44859	53831	62803	71775	80747	89719	98690				
		Minimum	18941	23676	28411	33146	37881	42616	47351	52087				
3TG301600	G3016	Start/End	47430	59288	71145	83003	94860							
		Minimum	25033	31291	37549	43807	50065							
3TG302000	G3020	Start/End	75266	94082										
		Minimum	39724	49654										

SPRING RETURN G1 PNEUMATIC ACTUATOR TORQUE CHART

Apollo Model No.	Reference Number	Spring Torque (In-Lbs) Start/Min/End	Operating Pressure (psig)											
			40	50	60	70	80	90	100	110	120	150	175	200
			Output Torque Start/Min/End (In-Lbs)											
3TG100804	G01008-SR4	11614					5551	7628	9706	11783	13861	20093	25287	30481
		5708					2439	3543	4648	5752	6849	10138	12880	15621
		10015					3783	5861	7938	10016	12093	18326	23520	28713
3TG100904	G01009-SR4	11614			4820	7469	10117	12765	15414	18062	20710	28655		
		5708			2051	3459	4866	6271	7669	9066	10464	14657		
		10015			3053	5701	8350	10998	13646	16295	18943	26888		
3TG101004	G1010-SR4	11614		6488	10000	13511	17023	20534	24046	27557				
		5708		2938	4804	6664	8518	10371	12224	14078				
		10015		4721	4232	11744	15255	18767	22278	25790				
3TG101204	G01012-SR4	11614	9063	14096	19130	24163								
		5708	4306	6973	9630	12286								
		10015	7296	12329	17362	22395								
3TG101404	G01014-SR4	11614	13413	19534	25654									
		5708	6613	9843	13073									
		10015	11646	17766	23887									
3TG100803	G01008-SR3	13598						6048	8126	10203	12281	18513	23707	28901
		6605						2523	3631	4735	5839	9143	11884	14625
		11445						3669	5746	7824	9901	16434	21327	26521
3TG100903	G01009-SR3	13598				5889	8537	11185	13834	16482	19130	27075		
		6605				2437	3850	5257	6665	8071	9469	13662		
		11445				3509	6157	8806	11454	14102	16751	24695		
3TG101003	G01010-SR3	13598		4908	8420	11931	15443	18954	22466	25977				
		6605		1904	3787	5653	7520	9376	11229	13082				
		11445		2529	6040	9552	13063	16574	20086	23597				
3TG101203	G01012-SR3	13598	7483	12516	17550	22583								
		6605	3289	5964	8634	11291								
		11445	5104	10137	15170	20203								
3TG101403	G01014-SR3	13598	11833	17954	24074									
		6605	5601	8848	12078									
		11445	9453	15574	21695									

SCOTCH-YOKE ACTUATORS

Torque Ratings G Series

SPRING RETURN G1 PNEUMATIC ACTUATOR TORQUE CHART (CONT.)

Apollo Model No.	Reference Number	Spring Torque (In-Lbs) Start/Min/End	Operating Pressure (psig)													
			40	50	60	70	80	90	100	110	120	150	175	200		
			Output Torque Start/Min/End (In-Lbs)													
3TG100802	G01008-SR2	15526									8443	10521	16753	21947	27141	
		7352									3692	4796	8109	10857	13598	
		13037									5692	7770	14002	19196	24390	
3TG100902	G01009-SR2	15526					6777	9425	12074	14722	17370	25315				
		7352					2800	4214	5622	7029	8437	12635				
		13037					4026	6674	3923	11971	14619	22564				
3TG101002	G01010-SR2	15526			6660	10171	13683	17194	20706	24217						
		7352			2736	4611	6477	8348	10202	12055						
		13037			3909	7420	10932	14443	17955	21466						
3TG101202	G01012-SR2	15526	5723	10756	15789	20823										
		7352	2228	4922	7597	10264										
		13037	2972	8005	13039	18072										
3TG101402	G01014-SR2	15526	10073	16194	22314											
		7352	4559	7811	11051											
		13037	7322	13443	19563											
3TG100801	G0108-SR1	18470									8599	14831	20025	25219		
		8749									3364	6703	9463	12223		
		14776									4516	10748	15942	21136		
3TG100901	G0109-SR1	18470						7503	1152	12800	15448	23393				
		8749						2764	4207	5623	7030	11253				
		14776						3420	6069	8717	11365	19310				
3TG101001	G01010-SR1	18470				8249	11761	15272	18784	22295						
		8749				3174	5071	6937	8803	10669						
		14776				4166	7678	11189	14701	18212						
3TG101201	G01012-SR1	18470		8834	13868	18901										
		8749		3492	6190	8865										
		14776		4752	9785	14818										
3TG101401	G01014-SR1	18470	8151	14272	20392											
		8749	3121	6405	9658											
		14776	4068	10189	16309											

SCOTCH-YOKE ACTUATORS

Torque Ratings G Series

SPRING-RETURN ACTUATOR

All published torques are guaranteed minimum values.

Apollo Model No.	Reference Number	Spring Torque (In-Lbs) Start/Min/End	Operating Pressure (psig)								
			40	50	60	70	80	90	100	110	120
			Output Torque Start/Min/End (In-Lbs)								
3TG200902	G2009-SR2	26818									14072
		12882									5964
		22074									8829
3TG201002	G2010-SR2	26818						13859	18810	22361	26611
		12882						5848	8110	10369	12628
		22074						8616	12866	17117	21368
3TG201202	G2012-SR2	26818			12159	18252	24344	30437	36530		
		12882			4926	8185	11423	14661	17896		
		22074			6915	13008	19101	25194	31286		
3TG201402	G2014-SR2	26818		12648	20057	27466	34875				
		12882		5191	9145	13082	17020				
		22071		7404	14814	22223	29632				
3TG201602	G2016-SR2	26818	14720	24500	34279						
		12882	6308	11506	16703						
		22074	9477	19256	29036						
3TG200901	G2009-SR1	30997									
		14742									
		25004									
3TG201001	G2010-SR1	30997							14871	19122	23373
		14742							5957	8249	10508
		25004							8248	12498	16749
3TG201201	G2012-SR1	30997					21106	27199	33291		
		14742					9303	12541	15779		
		25004					14482	20575	26668		
3TG201401	G2014-SR1	30997			16819	24228	31637				
		14742			7014	10962	14900				
		25004			10195	17604	25013				
3TG201601	G2016-SR1	30997		21261	31041						
		14742		9386	14583						
		25004		14638	24417						
3TG200904	G2009-SR4	20678						10155	13361	16567	19772
		9903						4185	5900	7603	9307
		16917						5998	9204	12410	15616
3TG201004	G2010-SR4	20678				11058	15308	19559	23810	28061	32311
		9903				4675	6935	9194	11453	13712	15956
		16917				6901	11152	15402	19653	23904	28155
3TG201204	G2012-SR4	20678		11766	17859	23952	30044	36137	42230		
		9903		5052	8290	11528	14760	17975	21191		
		16917		7609	13702	19795	25888	31980	38073		
3TG201404	G2014-SR4	20678	10939	18348	25757	33166	40575				
		9903	4610	8550	12488	16407	20318				
		16917	6782	14191	21600	29009	36419				
3TG201604	G2016-SR4	20678	20420	30200	39979						
		9903	9652	14842	20003						
		16917	16264	26043	35823						
3TG200903	G2009-SR3	24139								13833	17039
		11457								5833	7539
		19390								8584	11790
3TG201003	G2010-SR3	24139					12575	16826	21077	25327	29578
		11457					5150	7426	9685	11944	14203
		19390					7326	11577	15828	20078	24329
3TG201203	G2012-SR3	24139			15126	21219	27311	33404	39497		
		11457			6522	9760	12998	16236	19460		
		19390			9877	15970	22062	28155	34248		
3TG201403	G2014-SR3	24139		15615	23024	30433	37842				
		11457		6782	10720	14657	18587				
		19390		10366	17775	25184	32593				

SCOTCH-YOKE ACTUATORS

Torque Ratings G Series

SPRING-RETURN ACTUATOR (CONT.)

Apollo Model No.	Reference Number	Spring Torque (In-Lbs) Start/Min/End	Operating Pressure (psig)								
			40	50	60	70	80	90	100	110	120
			Output Torque Start/Min/End (In-Lbs)								
3TG201603	G2016-SR3	24139	17687	27467	37246						
		11457	7883	13081	18273						
		19390	12438	22218	31997						
3TG301002	G3010-SR2	49017									20655
		22571									6848
		36975									7346
3TG301202	G3012-SR2	49017						25456	32826	40195	47564
		22571						9568	13568	17516	21433
		36975						12147	19516	26886	34255
3TG301402	G3014-SR2	49017				21936	30907	39879	48851	57823	
		22571				7591	12527	17349	22117	26885	
		36975				8626	17598	26570	35542	44514	
3TG301602	G3016-SR2	49017			30278	42135	53993				
		22571			12185	18548	24849				
		36975			16968	28826	40683				
3TG302002	G3020-SR2	49017	34398	53215							
		22571	14422	24436							
		36975	21089	39905							
3TG301001	G3010-SR1	54045									
		25307									
		42224									
3TG301201	G3012-SR1	54045							27024	34394	41763
		25307							10497	14497	18420
		42224							13960	21329	28698
3TG301401	G3014-SR1	54045					25106	34078	43050	52022	
		25307					9456	14326	19104	23873	
		42224					12041	21013	29985	38957	
3TG301601	G3016-SR1	54045			24476	36334	48191				
		25307			9107	15535	21837				
		42224			11412	23269	35127				
3TG302001	G3020-SR1	54045	28597	47413							
		25307	11351	21423							
		42224	15532	34349							
3TG301004	G3010-SR4	36568							19695	24822	29949
		17123							7867	10637	13361
		28566							10851	15978	21105
3TG301204	G3012-SR4	36568				20012	27381	34751	42120	49489	56858
		17123				8038	11996	15913	19830	23746	27663
		28566				11168	18537	25906	33276	40676	48014
3TG301404	G3014-SR4	36568			22258	31239	40201	49173	58145	67117	
		17123			9257	14042	18810	23578	28347	33089	
		28566			13414	22385	31357	40329	49301	58273	
3TG301604	G3016-SR4	36568	15857	27714	39572	51429	63287				
		17123	5764	12174	18475	24777	31068				
		28566	7013	18870	30728	42585	54443				
3TG301003	G3010-SR3	42128								20609	25735
		19573								7746	10528
		32379								9833	14960
3TG301203	G3012-SR3	42128					23167	30537	37906	45275	52645
		19573					9135	13115	17032	20949	24865
		32379					12392	19761	27130	34500	41869
3TG301403	G3014-SR3	42128			18044	27016	35988	44960	53931	62903	
		19573			6305	11223	16012	20781	25549	30317	
		32379			7268	15240	25212	34184	43156	52127	
3TG301603	G3016-SR3	42128		23501	35358	47216	59073				
		19573		9315	15678	21980	28282				
		32379		12725	24582	36440	48297				
3TG302003	G3020-SR3	42128	39479	58295							
		19573	17868	27868							
		32379	28703	47519							

AE SERIES ACTUATORS

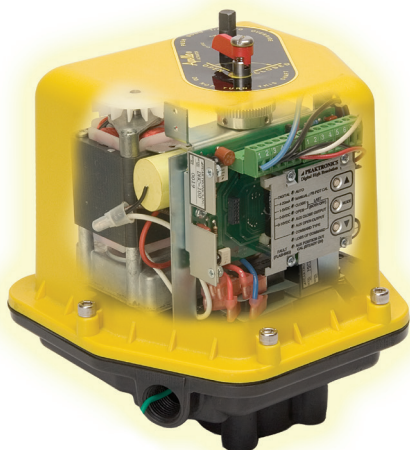

Ruggedly built and designed for easy installation, new Apollo® AE Series electric actuators deliver the most standard features and performance in their class. *Now CSA listed all sizes as standard.*

FIVE OUTPUT TORQUES, ONE HOUSING

- 200, 400, 600, 800 and 1,000 inch-pounds
- Long Service Life
- Anodized die cast aluminum housing
- Fiberglass reinforced nylon cover resists corrosion
- Nitrile gasket and seals cover all penetration points in housing and cover
- Precision cut and heat treated alloy spur gears
- Permanently lubricated enclosed gear train
- NEMA 4, 4X

EASY TO USE

- Two separate 1/2" NPT conduit entrances for easier wiring and signal separation
- 12-position pre-wired terminal strip includes standard connections for remote open/closed position indicators; lots of room for wiring options
- Unrestricted mounting orientation
- Built-in thermal overload protection in all AC motor actuators
- Limit switches have an 11 amp rating at 115 VAC
- High visibility valve position indicator standard on all models

MANY STANDARD FEATURES

- Stainless steel push-and-turn manual override shaft, position indicator shaft and female output
- ISO 5211 F07 drive output reduces inventory of mounting kits
- 115 AC & 220 AC models feature a 25% duty cycle below 100°F (24AC — 20% duty cycle below 100°F)
- 12 and 24 DC — all DC voltage models provide 100% duty cycle for 1 hour after which DC motor is reduced to 80% duty cycle.
- Reversible rotation

BROAD TEMPERATURE RANGE

- Operates from -40°F (when equipped with 15 watt heater and thermostat) to 150°F

AVAILABLE OPTIONS

- Actuators can be ordered with one, two or three additional limit switches
- For low temperatures: actuators can be equipped with a thermostatically controlled heater element
- Motor brake is necessary when mounting actuator to a butterfly valve

4-20MA POSITIONER FEATURES (P - OPTION)

Advanced Protection Features

- A) Stall Detection - Motor will not burn out from stalling
- B) Fault Signal
 - Fault LED on DHC-100 front panel
- C) Duty Cycle Protection
 - Allows actuators rated for 25% duty, or more, to be safely modulated
 - Activates prior to tripping of thermal overload protector, which prevents long shut down periods due to tripping thermal overload protector; allows the actuator to continue to move to set-point at a 25% duty cycle speed

Performance Features

- A) High Resolution ($\pm 0.1^\circ$)
 - 450 points of resolution on a 1/4 turn valve
- B) Dynamic Braking
 - Stops motor before changing actuator direction
 - Stops motor before mechanical brake engages, which reduces break wear
- C) Adaptive Control - Designed to maintain high resolution and accuracy by continuously monitoring and compensating for actuator backlash, motor coast, and load changes to eliminate positioner deadband

4-20MA POSITION TRANSMITTER FEATURES (T - OPTION)

- A) High Resolution Feedback Transmitter
 - Provides voltage or mA output that can be set for any range (0 to 10 VDC in 0.0016 V steps or 0 to 20 mA in 0.0031 mA steps)
- B) Auto/Manual Station (Local Control Unit - LCU)
- C) Polarity Detection



AE SERIES ACTUATORS

General Specifications

Actuator Model	Breakaway Torque Output (in.-lbs.)	Cycle Time 90° Travel (50% Load)	Duty Cycle	Amperage Draw (max.)			
				Starting or locked rotor current voltage			
				115 VAC	230 VAC	12 VDC	24 VDC
AE200	200 in-lbs	5.0 sec.	25%	.74 amp	.44 amp	1.6 amp	1.7 amp
AE400	400 in-lbs	10.0 sec.	25%	.74 amp	.44 amp	1.6 amp	1.7 amp
AE600	600 in-lbs	15.0 sec.	25%	.74 amp	.44 amp	1.6 amp	1.7 amp
AE800	800 in-lbs	20.0 sec.	25%	.74 amp	.44 amp	1.6 amp	1.7 amp
AE1000	1000 in-lbs	25.0 sec	25%	.74 amp	.44 amp	1.6 amp	1.7 amp

Note: 90° Travel = Travel From Closed position to Open position or vice versa.

DC current draw is at max. torque

24 VAC current draw at locked rotor 4.6 amp

Motor	AC models: 120 VAC or 230 VAC, Reversible 3 wire, capacitor run. Self-resetting (thermal) overload protection, Class B insulation, sub-fractional horsepower. DC models: 12 VDC or 24 VDC, Reversible 2 wire, POS & NEG. No thermal overload (external circuit breaker or fuse suggested for protection.)
Lubrication	Permanently lubricated gear train and bearings
Duty Cycle	The AE-Series actuators are designed to operate at 25% duty cycle at temperatures below 100° F. See Electrical Operation. (24 AC-20% duty cycle below 100° F)
Temperature Operating	32° F to 150° F Max
Range	-40° F to 150° F with optional heater & thermostat
Thermal Protection	Self-resetting (AC Motors Only)
Conduit Connections	(2) 1/2"-NPT female
Direction Of Travel	Clockwise to Close, Counterclockwise to Open (Position indicator shaft only, manual override shaft opposite)

AE Series Dimensions

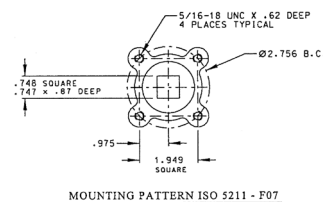
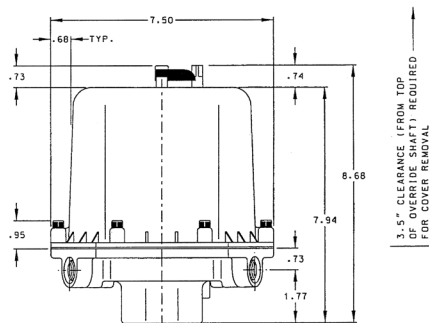
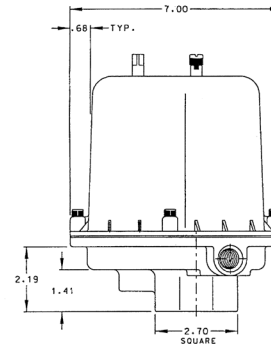
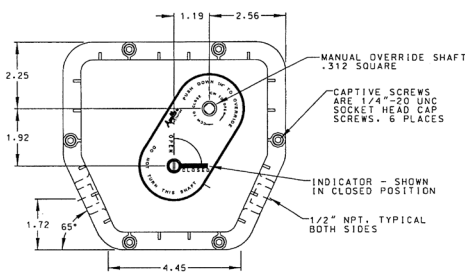

AE SERIES ACTUATORS

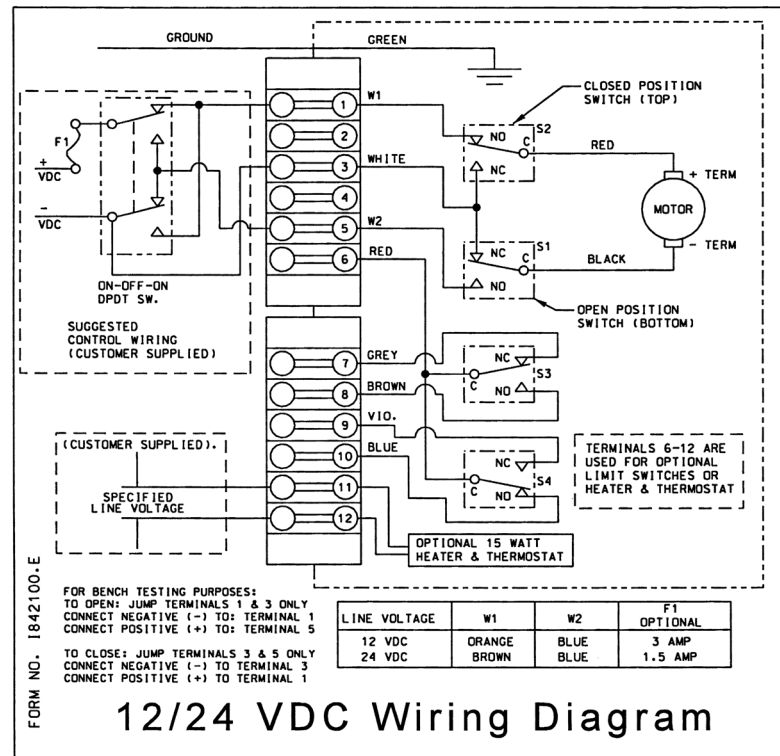
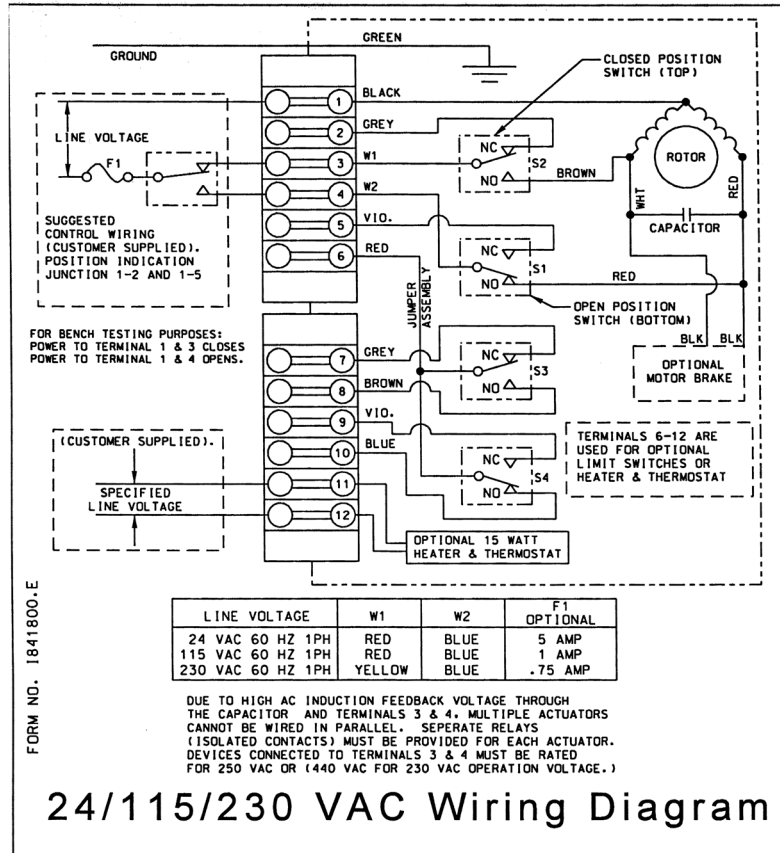

AE SERIES ACTUATORS

How to Order AE Series Electric Actuators



AE -	400 -	3	BF
PREFIX	TORQUE (LB - IN)	VOLTAGE	OPTIONS
AE	200	1 = 115 vac	0 = Standard
	400	2 = 24 vac	A = One extra switch & cam*
	600	3 = 220 vac	B = Two extra switches & cams*
	800		C = Three extra switches and cams*
	1000	4 = 12 vdc	D = Heater and Thermostat (15 watt)
	Enter all digits of Torque Value	5 = 24 vdc	F = Motor Brake (115 VAC & 24 VAC Only)
			H = Tropical Heater (15 watts)
			P = Positioner 4-20 mA
			T = Transmitter 4-20 mA

Note: AE will always be the first two characters of the part number, all digits from torque value must be entered into part number (i.e. 400, 1000, etc.) Only use one digit for voltage depiction (i.e. 1-5). For the options listing you may use more than one character, up to three, (i.e. O, AD or BD etc.)

Example:

AE-400-3BF :

400 lb. in.; 220 VAC; 2 extra switches and cams, motor brake

AE-1000-1D :

1000 lb. in.; 115 VAC; Heater and thermostat

- 1 Year warranty on positioner & positioner with transmitter
- Transmitter available with (P) positioner option only
- **Positioner & Transmitter are not CSA listed**
- * Not available with "P" option

CS & CL SERIES ACTUATORS



Conbraco's CS and CL electric actuators are split phase reversing AC motors for standard duty or brushless DC Motors for continuous duty. Eight sizes are available which produce breakaway torques between 150 and 3000 lb-in. They are excellent industrial quality units capable of on/off, fail safe, and modulating applications. The efficient spur gear drive train is supported by permanently-lubricated bearings making it very secure while eliminating the potential for side loading of the output shaft.

Conbraco offers as standard a 75% duty cycle AC motor. Continuous-duty brushless DC motors are also available for a range of input voltages. All units are rated for use in ambient environments from -40°F (with optional heater & thermostat) to 150°F (note that units equipped with an internal battery are rated to 130°F).

HAZARDOUS LOCATION ENCLOSURES

The standard enclosures (CS and CL) are rated for NEMA 4/4X (weather tight and corrosion resistant). The Hazardous Location enclosures are rated for NEMA 4/4X/7 & 9, Class I, Div 1, Groups C&D; Class II, Div. 2, Groups E, F, & G; Class III.

(CSA) CERTIFICATIONS

Certification by the Canadian Standards Association of either hazardous or weatherproof locations is standard on all CS & CL models.

FEATURES

- Plug-in connectors for the motor, the brake option and the heater/ thermostat option
- All connectors are coded to prevent mis-wiring.
- Limit switch wires are soldered to the board - no more loose connections.
- A six position terminal strip clearly labeled so it can be wired up in the field without an instruction manual.
- Thermal overload protection (AC motors)
- Dual conduit openings; 3/4" (1/2" with supplied bushings)
- Visual position indication
- All aluminum enclosure
- Captive cover bolts on CS Series
- Manual override shaft (optional handwheel override with declutchable shaft)

CS & CL SERIES ACTUATORS

INTRODUCING SIMPLICITY FOR CALIBRATING MODULATING ACTUATORS

The Control Board brings a whole new level of simplicity to the field. It will work with either of the Motor Boards (115VAC or 230VAC). Features include:

- Switch selector for 4-20mA or 0-10VDC input
- Switch selector for 4-20mA or 0-10VDC position readback
- Switch selector for either "fail in-place" or "fail to zero" upon loss of control signal (provided input power remains)
- On-board push buttons to manually position the actuator
- A "Mode Selector" switch with LEDs, which are used for:
 - "No tools" pot calibration
 - Setting Zero and Span
 - Manually positioning the actuator
- An adjustable pot for Speed Control (motor pulsing)
- An adjustable pot for deadband adjustment
- Locked Rotor Protection if the actuator cannot achieve the position commanded by the control signal, it will cut power to the motor. Repeated stalls will not damage the actuator.
- Reverse acting operation with no rewiring.
- Split range operation with no rewiring.

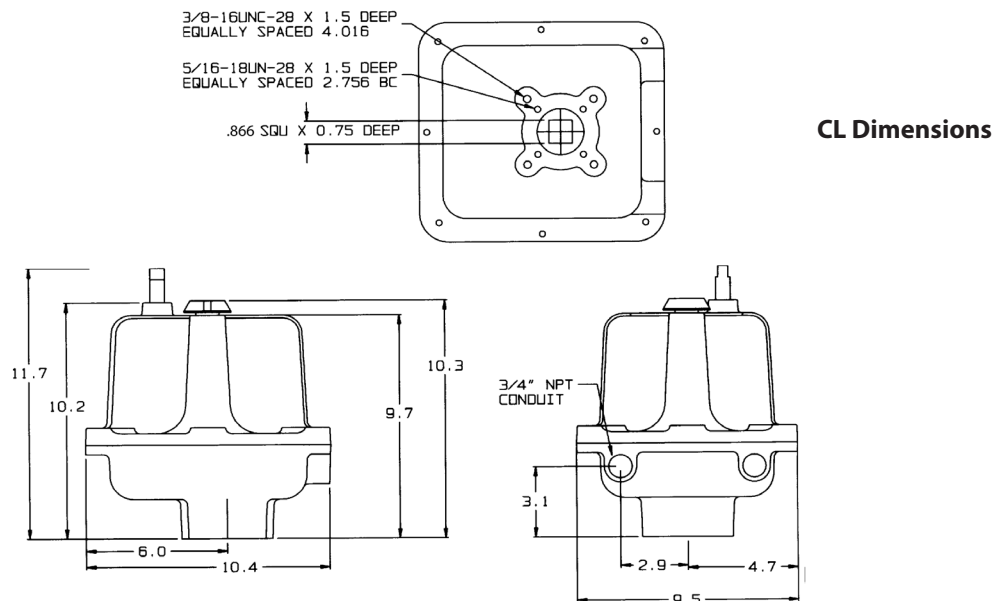
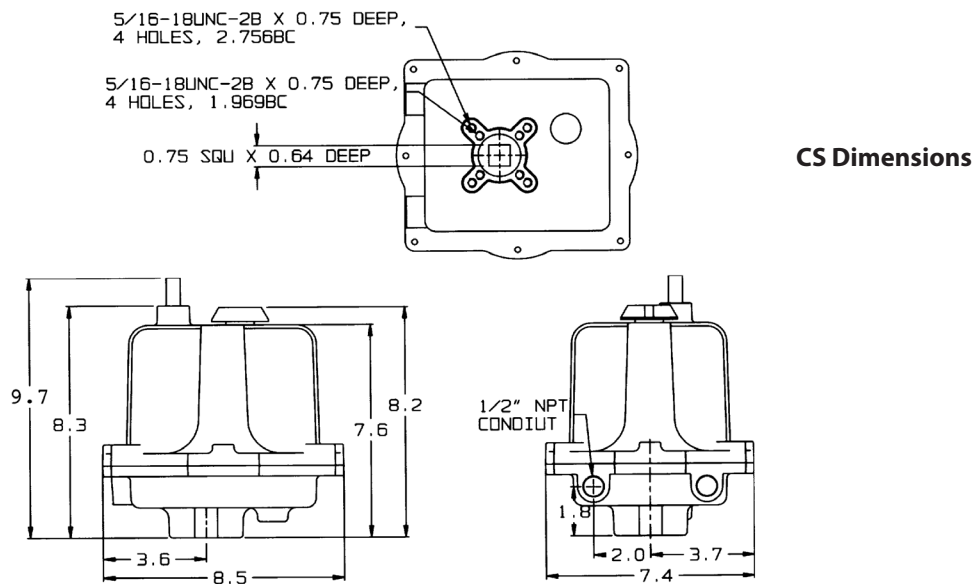

CS & CL SERIES ACTUATORS

Specifications and Options

CS & CL EXTENDED DUTY DATA

TECHNICAL DATA—115VAC AND 230VAC Models*

Series	Torque Output (breakaway)	Speed (seconds per 90° rotation)	Duty Cycle	VA Rating		Max Running Current at Full Load (True RMS)		Max Effective Peak Inrush Current (= .66 x peak inrush)	
				115 VAC	230 VAC	115 VAC	230 VAC	115 VAC	230 VAC
CS	150 in lb	8	75%	70vA	115vA	0.6 amps	0.5 amps	1.25 amps	0.924 amps
	300 in lb	15	75%	70vA	115vA	0.6 amps	0.5 amps	1.25 amps	0.924 amps
	600 in lb	30	75%	70vA	115vA	0.6 amps	0.5 amps	1.25 amps	0.924 amps
CL	1000 in lb	25	75%	92vA	161vA	0.8 amps	0.7 amps	1.66 amps	1.29 amps
	1500 in lb	40	75%	92vA	161vA	0.8 amps	0.7 amps	1.66 amps	1.29 amps
	2000 in lb	55	75%	92vA	161vA	0.8 amps	0.7 amps	1.66 amps	1.29 amps
	2500 in lb	70	75%	92vA	161vA	0.8 amps	0.7 amps	1.66 amps	1.29 amps
	3000 in lb	75	55%	92vA	161vA	0.8 amps	0.7 amps	1.66 amps	1.29 amps

CS & CL CONTINUOUS DUTY DATA

Series	Torque (In-Lb)	Duty Cycle	12 VDC		24 VDC		24 VAC		115 VAC		230 VAC	
			Cycle Time (sec/90°)	Current Draw Amps	Cycle Time (sec/90°)	Current Draw Amps	Cycle Time (sec/90°)	Current Draw Amps	Cycle Time (sec/90°)	Current Draw Amps	Cycle Time (sec/90°)	Current Draw Amps
CS	150	100%	11	2.2	13	1.2	8	1.8	9	0.4	9	0.4
	300	100%	17	2.5	13	1.4	12	2.1	13	0.5	13	0.4
	600	100%	17	2.8	13	1.7	13	2.5	14	0.6	14	0.5
CL	1000	100%	21	4	14	2.4	15	3.5	15	0.9	15	0.6
	1500	100%	40	4	24	2.4	27	3.5	29	0.9	29	0.6
	2000	100%	40	4.3	33	2.4	28	3.5	29	0.9	29	0.6
	2500	100%	55	3.3	40	2	38	3.1	39	0.8	39	0.6
	3000	100%	60	3.7	42	2.2	40	3.5	42	0.8	43	0.6

*Notes:

1. The Current Draws stated above include all options. If the brake and/or heater & thermostat are not installed, the actual current draws will be less.
2. For Extended Duty Cycle Models, Current Draws are provided at full running torque. If the actuator encounters an overtorque condition, such as a stall condition, the Current Draw will be vastly increased.
3. Continuous Duty actuators contain brushless DC motors and are therefore not limited by duty cycle restraints in environments at or below 104°F; in ambient environments above this temperature the duty cycle is de-rated to 80%.

ACTUATOR MODEL#s/DESCRIPTION

115 115 VAC Motor (Standard or Continuous)
 230 VAC 230 VAC Motor (Standard or Continuous)
 J Speed Control/Timer Board
 X NEMA 4,4X,7, & 9
 W NEMA 4 & 4X
 H Tropical Heater
 S2 Two Auxiliary Switches SPDT
 T Heater and Thermostat
 K Motor Brake²
 Z Declutchable Handwheel Override
 P Feedback Potentiometer (0-1000 Ohm)

• CSA certification with (C US) marking is standard on all standard (extended) duty models.
 • CSA certification with (C US) marking is standard on continuous duty models ordered with enclosure option "E".
² Standard on continuous duty cycle units

How to Order - CS & CL Extended Duty Cycle Actuator

CS & CL EXTENDED DUTY SERIES NUMBERING SYSTEM

SERIES	TORQUE	ENCLOSURE	GENERAL OPTIONS	DUTY CYCLE	VOLTAGE
CS	600	W	S2	E = Standard	115 VAC
CL	1500	X	S2	E = Standard	230 VAC

Contact Factory for Conbraco part number and price.



CS & CL SERIES ACTUATORS

How to Order - CS Continuous Duty Cycle Actuators

Example: Sample model code: 3RACS300WUL2Z

Prefix	Series	Torque	Enclosure	Options	Additional Options
3RA	CS	600	W	UL2	Z

Prefix
3RA

Series
CS

Torque	
150	150 in-lbs, 12 ft-lbs, 17 Nm
300	300 in-lbs, 25 ft-lbs, 34 Nm
600	600 in-lbs, 50 ft-lbs, 68 Nm

Enclosure	
W	NEMA 4/4X
X	NEMA 4/4X/7&9

Options ²	
U2	On/Off / Positioner Board
UL2	On/Off / Positioner Board w/ Battery Back-Up

Additional Options	
--	No Entry if Standard
Z	Handwheel

How to Order - CL Continuous Duty Cycle Actuators

Example: Sample model code: 3RACL2500XUL3

Prefix	Series	Torque	Enclosure	Options	Additional Options
3RA	CL	2500	X	UL3	-

Prefix
3RA

Series
CL

Torque	
1000	1000 in-lbs, 83 ft-lbs, 113 Nm
1500	1500 in-lbs, 125 ft-lbs, 169 Nm
2000	2000 in-lbs, 167 ft-lbs, 226 Nm
2500	2500 in-lbs, 208 ft-lbs, 282 Nm
3000	3000 in-lbs, 250 ft-lbs, 339 Nm

Enclosure	
W	NEMA 4/4X
X	NEMA 4/4X/7&9

Options ²	
U2	On/Off / Positioner Board
UL3	On/Off / Positioner Board w/ Battery Back-Up

Additional Options	
--	No Entry if Standard
Z	Handwheel

1. All Continuous Duty Cycle CS/CL actuators accept any of the following input voltage (12VDC, 24VDC, 24VAC, 115VAC, & 230VAC), are rated for continuous duty cycle, include a holding brake, two auxiliary limit switches, 4-20mA or 0-10VDC position feedback, wrench-operated manual override, CSA "C US" certification, CE compliance, and a heater/thermostat that can be user-enabled on the option board.

2. Only one board option can (and must) be selected. All board options can be configured for On/Off or modulating operation.

LB SERIES ACTUATORS

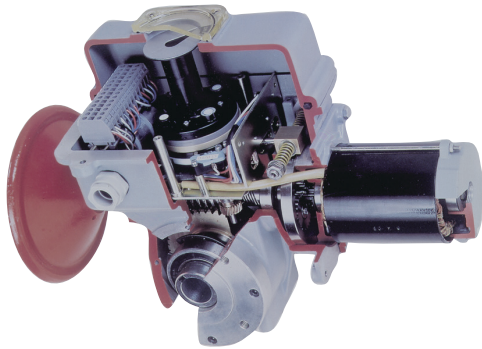

The LB-Series is available in several basic designs with a wide variety of configurations from which to select torque and speeds to meet specific application requirements. These rugged and uncomplicated actuators provide a practical and reliable method for turning any mechanism 90°. Torques range from 540 inch-pounds to 54,000 inch-pounds (6.25 to 625 kilogram-meters). Electrical models are available in 115 VAC-50/60 Hz single phase, 200 VAC-50/60 single phase; and 220/440 VAC-50/60 Hz three phase. Models are available for on/off modulating control.

Listed below are performance specifications for a limited sampling of LB-Series electric actuators. This product family is available with a such a variety of options and features that they can not be represented in this catalog. Options such as positioners, transmitters, special enclosure ratings, extra switches, or motor voltages are optionally available. Contact Conbraco's Actuator Engineering Department for the proper actuator to fit non standard or unique requirements.

3R - AD - M - 05 - B - X - F

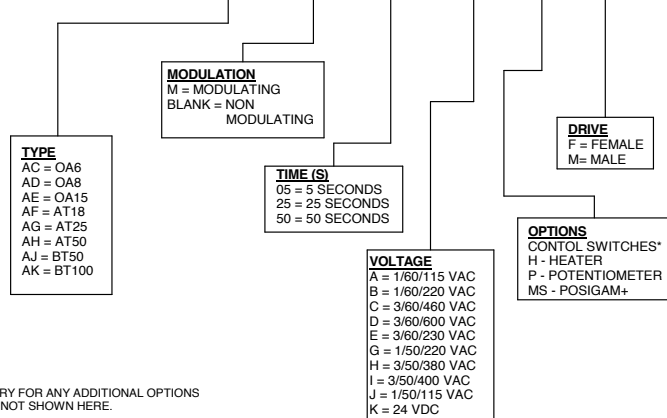

LB SERIES ELECTRIC ACTUATOR PERFORMANCE DATA

L-B Series Model Number	Torque Output Lb-In	Rotating Speed (Sec/90 degree)		Power Requirements 30% Duty Cycle			
				115VAC 1 Ph 60Hz		460 VAC 3 Ph 60 HZ	
		Std	Opt	RATED	START	RATED	START
OA8	885	5		1.95	3.3	0.63	1.15
OA8	885	25		1.25	2	0.39	0.78
OA15	1350	15	25	1.95	3.3	0.39	0.78
AT25	2250	15		1.95	3.3	0.63	1.15
AT25	2250	25	50	1.95	3.3	0.39	0.78
AT50	4500	25		4.6	12	0.63	1.15
AT100	8850	24	12	4	17	0.6	1.2

Contact factory for part numbers of actuators with options & other voltages

Notes:

- Operating speed is based on an actuator operating at rated output torque. Actual operating speed will vary depending on actual output torque.
- All torque and speed ratings are based on a plus or minus 10% motor voltage variation.
- All torque ratings represent the maximum torque available during both breakaway (start) and run (dynamic) conditions.
- Each actuator is supplied, as standard, with a 30% duty cycle, F insulation, TENV design motor rated for 360 starts per hour at 104°F.
- All actuators are NEMA 4 rated as standard. Many are optionally available with additional ratings, such as, explosion proof or submersible, etc., to meet special service requirements.
- All actuators utilize a self-locking gear train design and have provision for manual override.
- All actuators have both electrical and mechanical travel stop provisions.
- FQ Series are Spring Return Failsafe models. Contact factory for model number and price (not listed above).

LB SERIES ACTUATORS

Dimensions

TYPES OA8 AND OA15

Standard specification: Weatherproof NEMA 4, with two adjustable SPDT limit switches; with built-in motor thermal cutouts, with handwheel for manual operation. Duty rating 30%.

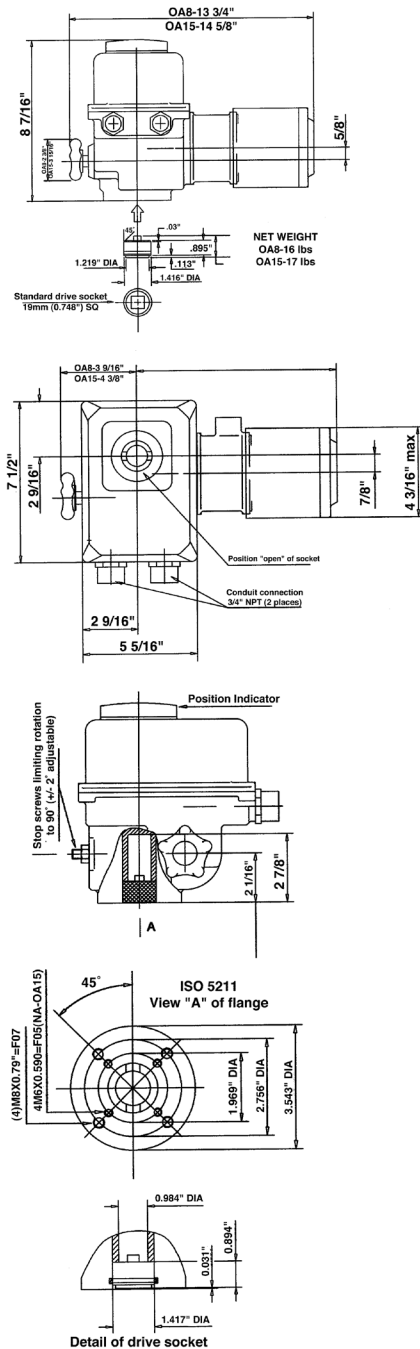

TYPES AT25 AND AT50

Standard specification: Weatherproof to NEMA 4, fitted with two adjustable SPDT travel limit switches (one for each extreme position); two SPDT torque limit switches (one for each direction of rotation) and with handwheel for manual operation.

Duty rating 30%. Net weight: 40 lbs.

AT25 female socket dimension = .866 square

AT50 female socket dimension = 1.063 square

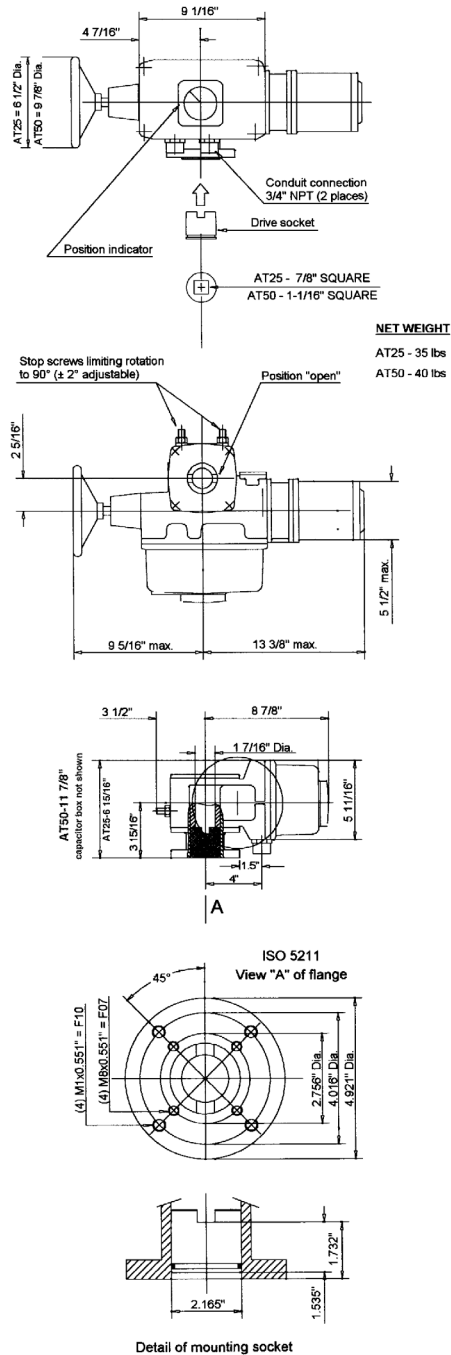

LB SERIES ACTUATORS

Dimensions

TYPE AT100

Standard specification: Weatherproof to NEMA 4, fitted with two adjustable SPDT travel limit switches (one for each extreme position); two SPDT torque limit switches (one for each direction of rotation) and with handwheel for manual operation. Duty rating 30%.

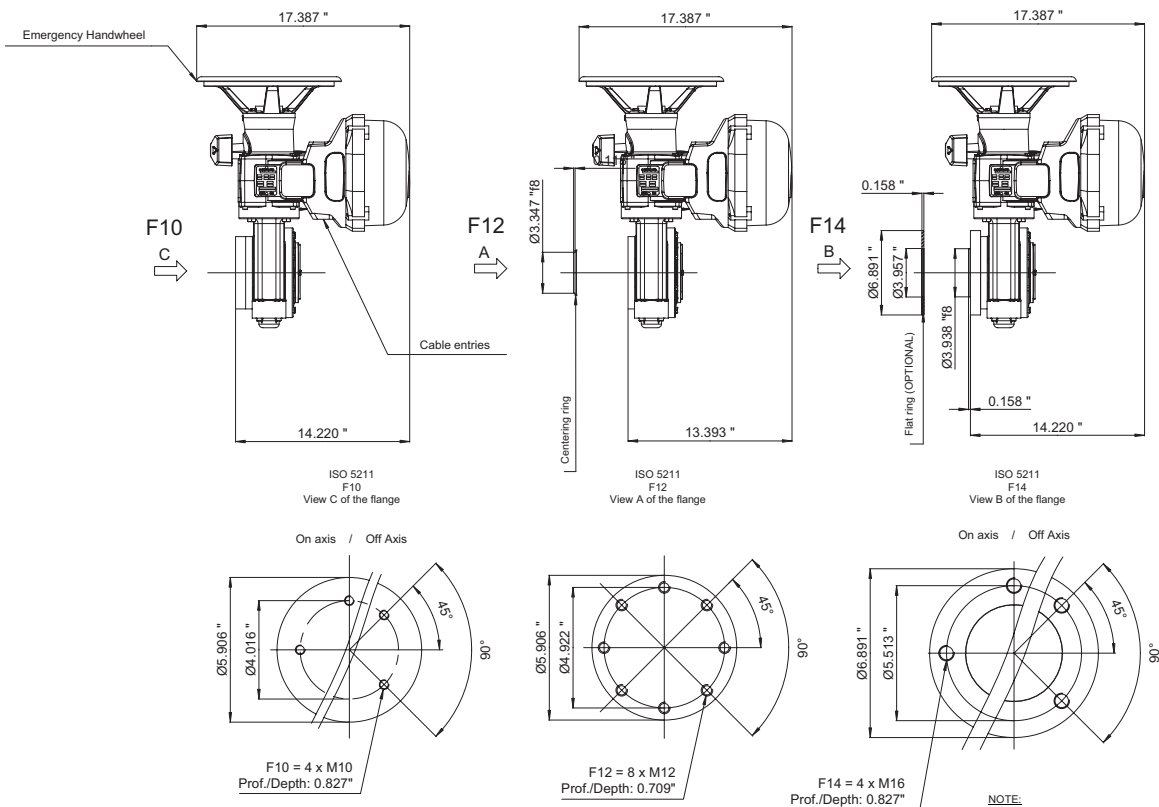
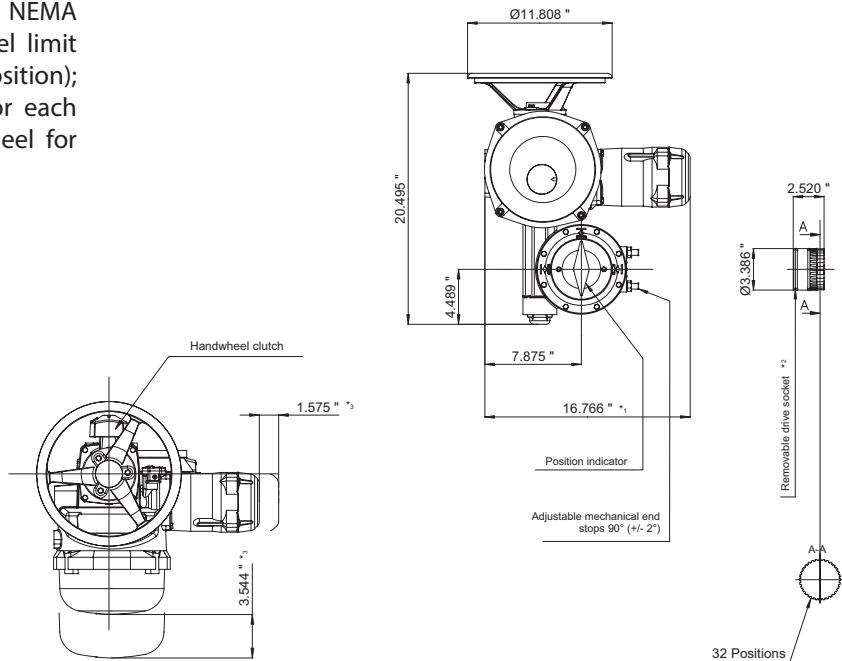

NOTE:

- *1 The actuator is represented in its maximum size.
- *2 Representation of the socket in closed position.
- *3 Dimension to allow for disassembly

SOLENOIDS

General Specifications

DIRECT MOUNTED NAMUR SOLENOID VALVES

TEMPERATURE LIMITS:

Media: 0°F to +180°F.

Ambient:

1: NEMA 4, 4X, 0°F to +180°F.

2: NEMA 4-4X-7-9, 0°F to +125°F.

COIL RATINGS:

1: NEMA 4, 4X: Continuous duty molded Class H insulation.

2: NEMA 4-4X-7-9: Continuous duty molded Class F

POWER CONSUMPTION:

6 Watts

MATERIALS:

Valve Body=Aluminum, anodized.

Fasteners=Stainless Steel

Seals & O-Rings=Nitrile.

CV FLOW RATE:

1.8

COIL VOLTAGES AVAILABLE:

Coil Voltage Variation: +/-10% of Nominal

1: 120 VAC-60 Hz/110 VAC-50 Hz.

2: 240 VAC-60 Hz/220 VAC-50 Hz/120 VDC.

3: 48 VAC-60 Hz/44 VAC-50 Hz/24 VDC.

4: 24 VAC-60 Hz/22 VAC-50 Hz/12 VDC.

NEMA 4-4X UL, CSA, PTB&CE

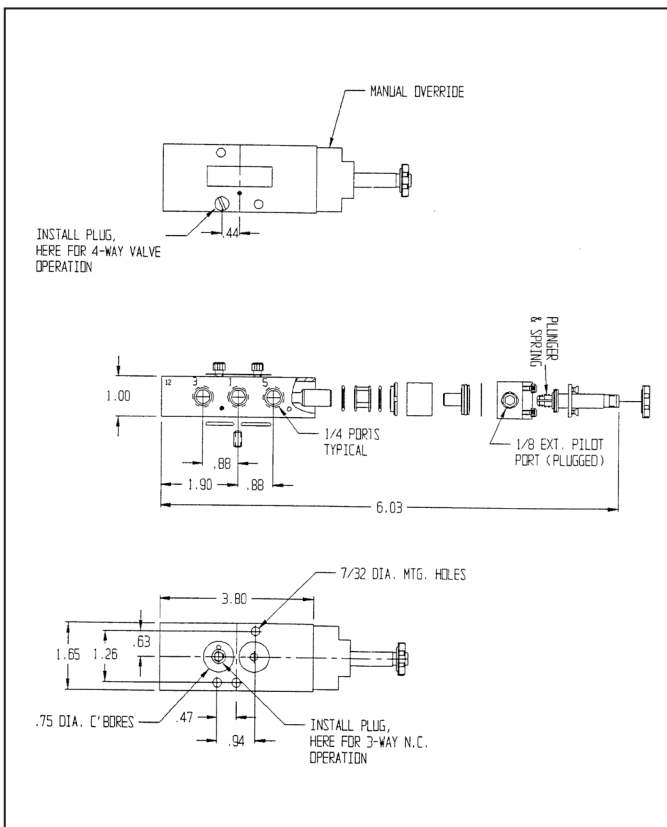

NEMA 4, 4X, 7 & 9 UL, CSA, PTB&CE

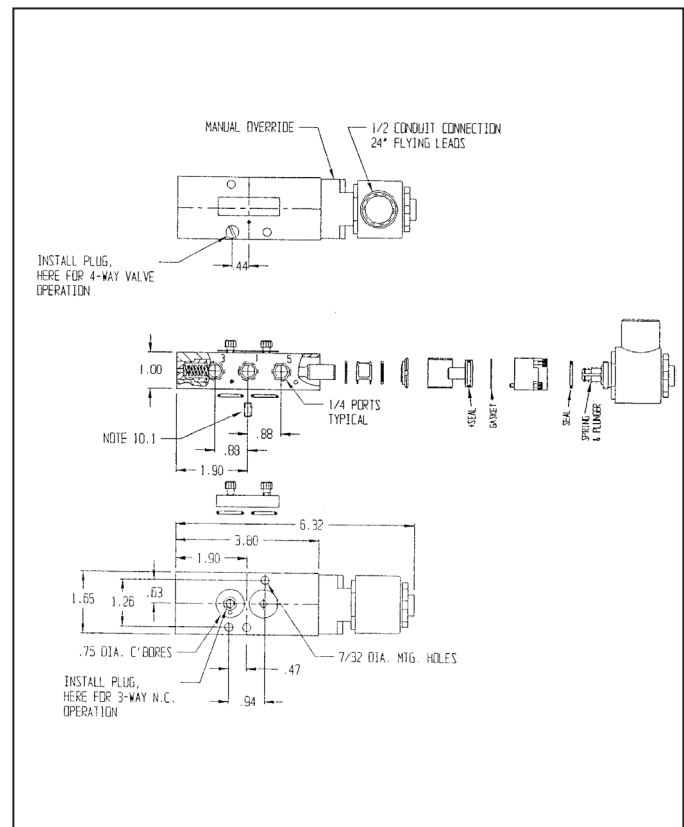

SOLENOIDS

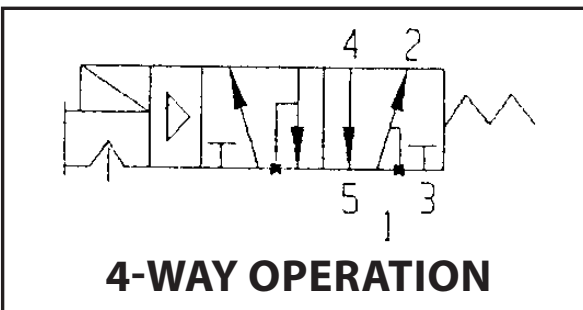
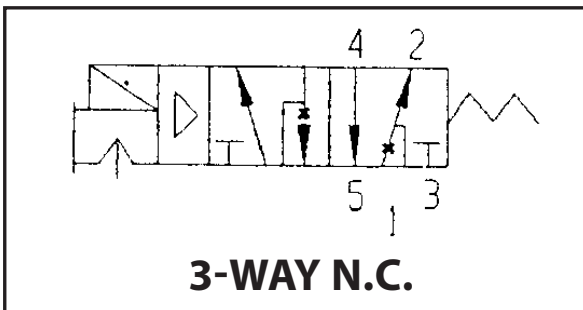
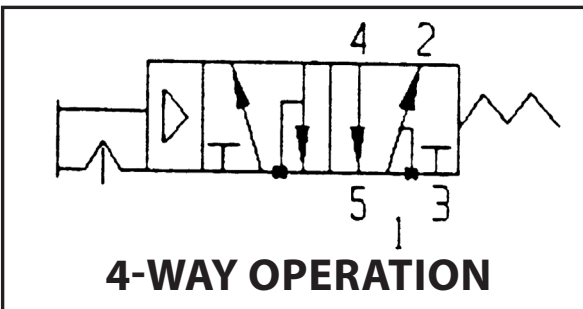
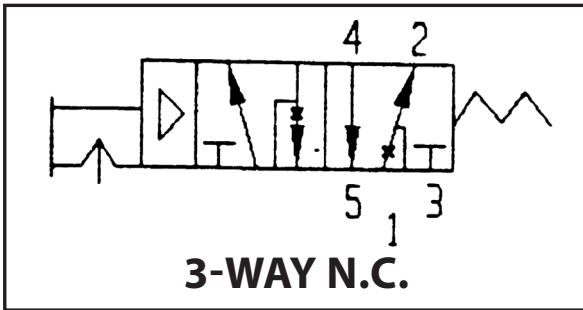

SOLENOID VALVES

AVC NAMUR *Three & Four-way, end mounted coil

Solenoids: Cv=1.8

For NAMUR Direct Mount

Part No.		
3T8-411-40A	115 VAC NEMA 4	0025 thru 4000
3T8-421-40A	12 VDC/24 VAC NEMA4	0025 thru 4000
3T8-431-40A	24 VDC/48 VAC NEMA4	0025 thru 4000
3T8-441-40A	220 VAC NEMA4	0025 thru 4000
3T8-711-40A	115 VAC NEMA7	0025 thru 4000
3T8-721-40A	12 VDC/24 VAC NEMA7	0025 thru 4000
3T8-731-40A	24 VDC/48 VAC NEMA7	0025 thru 4000
3T8-741-40A	220 VAC NEMA7	0025 thru 4000

Part No.		
3T8-411-32A	115 VAC NEMA 4	032, 200 & 270
3T8-421-32A	12 VDC/24 VAC NEMA4	032, 200 & 270
3T8-431-32A	24 VDC/48 VAC NEMA4	032, 200 & 270
3T8-441-32A	220 VAC NEMA4	032, 200 & 270
3T8-711-32A	115 VAC NEMA7	032, 200 & 270
3T8-721-32A	12 VDC/24 VAC NEMA7	032, 200 & 270
3T8-731-32A	24 VDC/48 VAC NEMA7	032, 200 & 270
3T8-741-32A	220 VAC NEMA7	032, 200 & 270

All above include adapters to turn "NAMUR 90°"

Part No.		
3T8-000-32B	Adapter	032, 200 & 270
3T8-000-32A	Adapter	0025-4000

NAMUR Solenoid Valve with Transition Plate

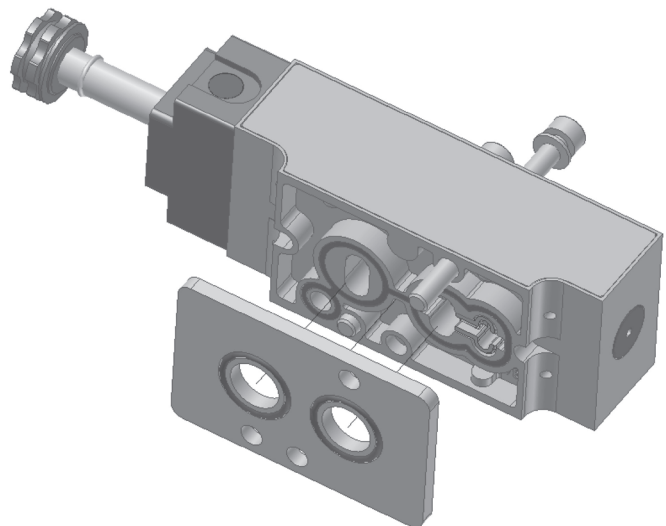

SOLENOIDS

Stonel Quartz Limit Switch

The Quartz is available in explosion proof (QX), nonincendive and intrinsically safe (QN) and general purpose (QG) versions. The robust epoxy coated anodized aluminum construction makes this platform extremely durable and well suited for use in corrosive, heavy wash down environments. A broad range of switching, position transmitter and communication options may be selected to accommodate most applications.

This versatile platform adapts to a wide variety of valve systems. Attach the Quartz to quarter-turn actuators, manual operators, linear operators and positioners using readily available stainless steel mounting systems.

1. Enclosures Optimized for Environment

QX: Explosion proof, water tight and corrosion-proof enclosure is approved for use in div. 1/zone 1 hazardous areas.

QN: Nonincendive is approved for all div.2/zone 2 hazardous environments with proximity sensors using a clear cover. Intrinsically safe Namur sensors or passive switches are available for div. 1/ zone 0 applications.

QG: General purpose features a clear Lexan cover with mechanical switches. All enclosures are rated NEMA 4, 4x, and 6.

2. Rapid Enclosure Access

Screw-on cover allows quick enclosure access, saving you valuable maintenance and set-up time. The cover provides a vapor tight seal and allows entry to internal components in less than five seconds.

3. Faster Wiring

Pre-wired and labeled terminal strip enables quick, convenient attachment of field wires.

4. Wide Variety of Switching & Communication

Switching options include dual module sensors and communication, Maxx-Guard proximity switches and mechanical switches. Continuous signal output is available in a 4 to 20 mA position transmitter.

5. Quick Set Cams are Easy to Adjust

Touch and Tune switch settings allow you to make adjustments in seconds without the use of tools.

6. Dual Shaft O-ring Seals Eliminate Corrosion

Top inner and bottom outer shaft o-rings seal the drive bushing from both external corrosives and internal contaminants that enter the enclosure.

7. Special Drive Bushing Assures Long Cycle Life

The oil impregnated bronze bushing maintains smooth operation and eliminates the potential for shaft seizure due to actuator shaft eccentricity.

8. Space Saving Visual Indication

Visual indicator offers excellent view ability without sacrificing accessibility or adding to space requirements. Indicators are also available with continuous percentage or three-way indication.



Moniteur Limit Switches

Moniteur Limit Switches have been designed to provide the most visible and reliable valve position indication in general purpose, difficult process, and explosion-proof environments. With a wide variety of switches and sensors available to match your application.

Features Include:

- The industry's only "true" visual valve position indicator available for multi-port valves, adjustable to match the actual physical flow pattern of the valve.
- Patented engineered Loc-Ring Cam and Shaft Retention System provides unsurpassed sensing accuracy over the multi-million cycle life of the physical platform.
- Clear Ektar cover offers optimum chemical resistance and strength and is environmentally sealed to prevent fogging and entry of contaminants.
- Indicator is fully adjustable to any valve or actuator.
- Internal switches and terminal block are labeled for easier installation.
- Careful material selection provides a rated life of minimum 1,000,000 cycles.
- Materials of construction selected to excel in high vibration, corrosive, and dirty environments, either indoors or outdoors.
- "Flat cover" version is available without an indicator for areas with tight space requirements.

Part Number	Model No.	Description
3T-LS3-02	FMYB-5120	NEMA 4/Indicator/2 SPDT Mech.
3T-LS3-06	FFNB-5120	NEMA 4/Flat Cover/2 SPDT Mech.
3T-LS3-01	AMYB-5120	NEMA 7/Indicator/2 SPDT Mech.
3T-LS3-05	AFNB-5120	NEMA 7/Flat Cover/2 SPDT Mech.
3T-LS3-03	AMYB-5220	NEMA 7/Indicator/2 SPDT Prox.
3T-LS3-07	AFNB-5220	NEMA 7/Flat Cover/2 SPDT Prox.
3T-LS3-04	FMYB-5220	NEMA 4/Indicator/2 SPDT Prox.

See Page 42 for Part Numbering Matrix

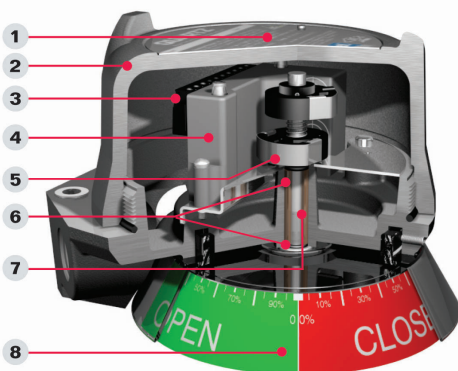

Part Number	Actuator Size
63-002-12	0012
63-002-13	0025-0350
63-002-14	0600-4000

*Short shaft NAMUR must use kits above.



SOLENOIDS

Stonel Quartz Limit Switch - How to Order

Explosion proof Quartz Models (Aluminum Cover)					
Series	Sensors/Switches	Enclosure	Conduit Entries	Indicator	
QX	Sensor Modules		E	North American (NEC/CEC)	02 (1) 3/4" NPT & SRA Red-Closed / Green-Open
	33	SST N.O. Switching Sensor Dual Module	R	International (IEC/ATEX)	(1) 1/2" NPT SGA Green-Closed / Red-Open
	Valve Communication Terminals (VCTs)		F	INMETRO	03 (1) 3/4" NPT & S1A T1 3-way
	92	DeviceNet VCT	S*	Stainless Steel North American (NEC/CEC)	(2) 1/2" NPT S2A T2 3-way
	93	Foundation Fieldbus	T*	Stainless Steel International (IEC/ATEX)	05 (2) M20 S3A T3 3-way
	96	AS-Interface	M*	Stainless Steel INMETRO	06 (3) M20 S4A T4 3-way
	97	AS-Interface (w/ extended addressing)			S5A T5 3-Way
	Mechanical Switches				S0A No Indication
	2V	(2) SPDT Mechanical Switches			SXA Special
	2W	(2) SPDT Gold Contact Mechanical Switches			SCA Continuous
	4V	(4) SPDT Mechanical Switches			
	4W	(4) SPDT Gold Contact Mechanical Switches			
	14	(2) DPDT Mechanical Switches			
	5V	Position Transmitter w/ (2) SPDT Mechanical Switches			
	5W	Position Transmitter w/ (2) SPDT Mechanical Switches			
	Expeditors (Proximity Type)				
	82	DeviceNet			
	86	AS-Interface			
	Sensors/Switches				
	Function		Switch/Sensor Type		
	2	(2) Switches	P	SPST Maxx-Guard	
	4	(4) Switches	L	SPST Maxx-Guard (LED)	
	5	Position Transmitter w/ (2) or No Switches	G	SPDT Maxx-Guard	
	7	High Performance Position Transmitter w/ (2) or No Switches	H	SPDT Maxx-Guard	
	8	Expeditor, Y or H switches only	S	SPDT Maxx-Guard (LED)	
			Y	Expeditor Only (3)	
		F	PNP Solid State 3-Wire P&F		
		X	SST Sensor (LED)		
		O	No Switches		

Nonincendive & Intrinsically Safe Quartz Models (Clear Cover)					
Series	Sensors/Switches	Enclosure	Conduit Entries	Indicator	
QN	Sensor Modules		C	North American (NEC/CEC)	02 (1) 3/4" NPT & SRA Red-Closed / Green-Open
	33	SST N.O. Switching Sensor Dual Module	D	International (IEC/ATEX)	(1) 1/2" NPT SGA Green-Closed / Red-Open
	44	Namur Sensors Dual Module I.S.; DIN 19234			03 (1) 3/4" NPT & S1A T1 3-way
	Valve Communication Terminals (VCTs)				(2) 1/2" NPT S2A T2 3-way
	92	DeviceNet VCT			05 (2) M20 S3A T3 3-way
	93	Foundation Fieldbus			06 (3) M20 S4A T4 3-way
	96	AS-Interface			S5A T5 3-Way
	97	AS-Interface (w/ extended addressing)			S0A No Indication
	Expeditors (Proximity Type)				SXA Special
	82	DeviceNet			SCA Continuous
	86	AS-Interface			
	Sensors/Switches				
	Function		Switch/Sensor Type		
	2	(2) Switches	P	SPST Maxx-Guard	
	4	(4) Switches	L	SPST Maxx-Guard (LED)	
	5	Position Transmitter w/ (2) or No Switches	G	SPDT Maxx-Guard	
	7	High Performance Position Transmitter w/ (2) or No Switches	H	SPDT Maxx-Guard	
	8	Expeditor, Y or H switches only	S	SPDT Maxx-Guard (LED)	
			Y	Expeditor Only (3)	
			F	PNP Solid State 3-Wire P&F	
			X	SST Sensor (LED)	
			O	No Switches	
	Intrinsically Safe Type				
			J	SPST (Passive)	
			M	SPDT (Passive)	
			N	P + F Namur Sensors	

General Purpose Quartz Models (Clear Cover)					
Series	Function	Enclosure	Conduit Entries	Indicator	
QG	Mechanical Switches		C	General Purpose	02 (1) 3/4" NPT & SRA Red-Closed / Green-Open
	2V	(2) SPDT Mechanical Switches			(1) 1/2" NPT SGA Green-Closed / Red-Open
	2W	(2) SPDT Gold Contact Mechanical Switches			03 (1) 3/4" NPT & S1A T1 3-way
	4V	(4) SPDT Mechanical Switches			(2) 1/2" NPT S2A T2 3-way
	4W	(4) SPDT Gold Contact Mechanical Switches			05 (2) M20 S3A T3 3-way
	14	(2) DPDT Mechanical Switches			06 (3) M20 S4A T4 3-way
					S5A T5 3-Way
					S0A No Indication
					SXA Special
					SCA Continuous

See price list or contact factory for Conbraco P/N and price.



VRC POSITIONERS

Dimensional Diagrams

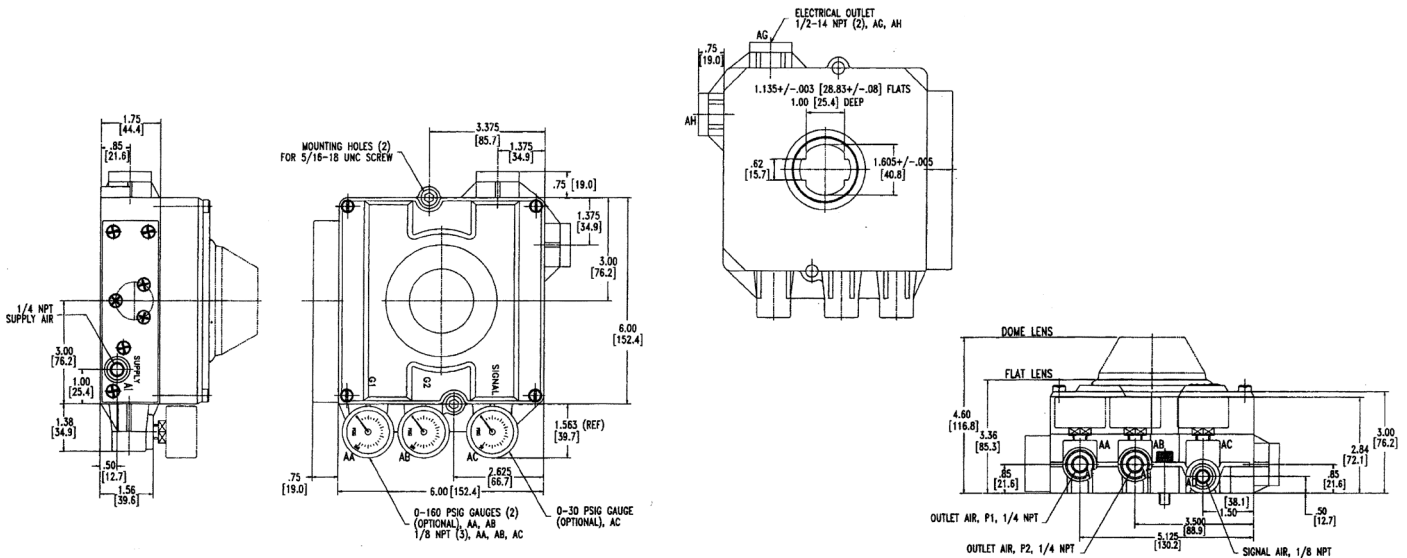

CONSTRUCTION

Part	Materials
Enclosure	PPA Composite, 300 Stainless Steel Port Rings, Cover and Mounting Bolts
Indicator Lens	LEXAN™
Internals	PPA, PPS and PEEK Composites 300 Series Stainless Steel
Nickel Plated Brass Spool Valve	Carpenter 70 Grade Stainless Steel
I/P Converter (VK02) VE Model	PPA Composite, TEFLON™ Coated Carbon Steel, Nickel Plated Carbon Steel, High Density Polyethylene DELRIN™
Signal Diaphragm/ O-Rings	BUNA N

PERFORMANCE

Parameter	Specification
Resolution	1.25% Maximum 0.10% Typical
Repeatability	99.75% Minimum 99.90% Typical
Hysteresis	0.50% Maximum 0.25% Typical
Linearity	1.0% Maximum
Gain @80 psig	250 Single Acting 500 Double Acting
Air Consumption @80 psig	0.25 SCFM – Standard Flow Spool Valve 0.45 SCFM – Maximum Flow Spool Valve
Temp. Range	-40 to 150°F / -40 to 65°C

How to Order VRC Positioners

3PV -					
PREFIX	POSITION INDICATOR & TYPE	SPOOL VALVE	PORT GAUGES	POSITION TRANSMITTER	LIMIT SWITCH
3PV	0 = Flat Pneumatic 1 = Flat Electro-Pneumatic 5 = Dome Pneumatic 6 = Dome Electro-Pneumatic	7 = Standard Flow 8 = Max Flow	3 = No Gauges 4 = Brass Gauges 5 = SS Gauges	0 = No Transmitter F = 4-20MA Current Output 2-Wire	0 = No Switch K = Mechanical Switch M = Proximity Switch

Note: See Price List for Apollo Part Numbers

PMV POSITIONERS

Features & Benefits



Simple design makes this product easy to understand, calibrate and repair. Rugged construction provides operation in a variety of tough applications. Compact size minimizes space requirements. A complete package means the user can select the right positioner for his application.

A bright indicator makes it easy for operators to visually check valve position. Spool valve design requires very little maintenance. Electro-pneumatic unit eliminates the need for an extra product and additional connections. Recognized product name means a proven product with many years of service.

PRODUCT SPECIFICATIONS

	P2000/20	P5/EP5*
Connections:	1/4"	1/4"
Supply Pressure:	120 psig	145 psig
Hysteresis:	0.5%	0.5%
Linearity:	2.0%	0.5%
Repeatability:	0.5%	0.5%
Sensitivity:	0.5%	0.25%
Input Signal:	4-20 mA	3-15, 4-20mA
Temperature - Standard:	+5 - 175°F	+5 - 185°F
Temperature - Optional:	+5 - 230°F	+5 - 230°F
Weight:	5.9 lbs.	2.9/4.1 lbs.
Air Consumption @ 85 psig:	35/.71 scfm-----	.75 scfm
Air Delivery @ 57 psig:	12/15.7 scfm	12.6 scfm
Gain Factor:	50/400	10,000

*PMV New Modular Unit P5-Pneumatic; EP5 Electropneumatic

Valve positioners are an excellent tool for increasing the gain of your valve package, often reducing your actuator size due to your increased ability to accurately control higher air deliveries, and the flexibility to add options and accessories to complete your control package's performance.

Our standard positioners include both pneumatic and electropneumatic positioners. Electropneumatic Positioners may be used on either double acting or spring return actuators. The anodized aluminum housing provides excellent product integrity and good corrosion resistance. Options including special coatings, stainless steel housings, and a variety of accessory items which provide the flexibility to meet your most demanding control applications.

PMV MOUNTING KITS FOR APOLLO ACTUATORS

Actuator Size	Mounting Kit	Material
AD/AS 0012	63-002-01	Stainless Steel
AD/AS 0025-0350	63-001-89	Stainless Steel
AD/AS 0600-4000	63-001-91	Stainless Steel

PART NUMBERS

Apollo Part #'s	PMV Model #'s	Description
3T-200-01	P-2000	Double Acting, Electro-Pneumatic, 1
3T-202-01	P-2020	Double Acting, Electro-Pneumatic, 2
3T-500-01	P5	Double Acting, Hi Capacity & Gain
3T-250-01	EP5	Electro Pneumatic, Hi Capacity & Gain
3T-250-02	EP5-EX	Double Acting, Hi Capacity & Gain, Explosion Proof

1. Normal Capacity
2. High Capacity
3. Accessories such as pressure gauges, limit switches, transmitters, and potentiometers are available. Please consult the factory for pricing.

PROXIMITY VALVE POSITION MONITORING SYSTEMS

VALVE POSITION MONITORING SYSTEMS

Proximity Controls' flexible Valve Position Monitoring Systems give users the ability to reliably monitor both manual and actuated valves. The durable position monitoring system features mounting hardware available in zinc plated steel, stainless steel, and Namur standards for all Proximity indicator models.

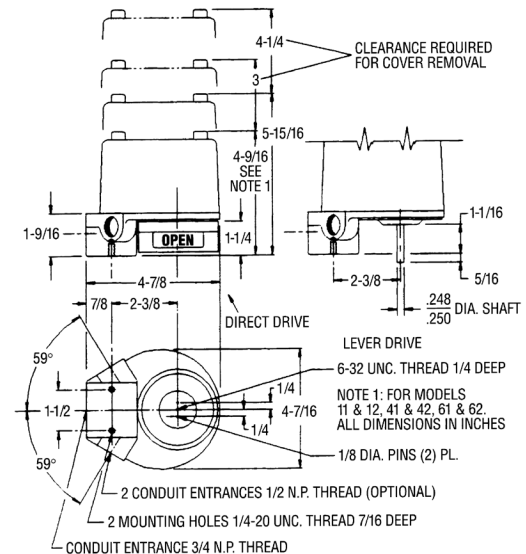

Proximity Model #	NEMA	Model Description	Switch/Transmitter Specifications
42ADM	4,4X	2 SPDT MECH, Clear Plastic Cover	15 amps ac, 5 amps dc
42AD0	4,4X,7,9	2 SPDT MECH, Anodized Aluminum Housing	15 amps ac, 5 amps dc
42DD0	4,4X,7,9	2 DPDT MECH, Anodized Aluminum Housing	10 amps ac, 10 amps dc
42RD0	4,4X,7,9	2 SPDT PROX, Herm Sealed Reed, Anodized Al.	3 amps ac, 2 amps dc
42VDOJ1	4,4X,7,9	2 SPDT MECH, 3/4" & 1/2" NPT Entry, Anodized Al.	10 amps ac, 10 amps dc
42RDOJ1	4,4X,7,9	2 SPDT PROX, 3/4" & 1/2" NPT Entry, Anodized Al.	3 amps ac, 2 amps dc
44AD0	4,4X,7,9	4 SPDT MECH, Anodized Aluminum Housing	15 amps ac, 5 amps dc
45VDO	4,4X,7,9	2 SPDT MECH, & Transmitter, Anodized Aluminum	10 amps / 4-20 mA out
45RD0	4,4X,7,9	2 SPDT PROX, & Transmitter, Anodized Aluminum	3 amps / 4-20 mA out
62PDO	4,4X,7,9	2 SPST PROX, Anodized Aluminum Housing	Herm Sealed Reed (mA)
62QD0	4,4X,7,9	2 SPDT PROX, Anodized Aluminum Housing	Herm Sealed Reed (mA)
35OD0*	Mag Coupling	MULTI-TURN Transmitter, Anodized Aluminum	No Switch / 4-20 mA
12AD0**	Mag Coupling	2 SPDT MECH, Anodized Aluminum Housing	15 amps ac, 5 amps dc
15VDO	Mag Coupling	2 SPDT MECH, & Transmitter, Anodized Aluminum	10 amps / 4-20 mA out
12VDOJ1	Mag Coupling	2 SPDT MECH, 3/4" & 1/2" NPT Entry, Anodized Al.	10 amps ac, 10 amps dc
12AD6	Mag Coupling - ST STL	2 SPDT MECH, 304 Stainless Steel Housing	15 amps ac, 5 amps dc
15VD6	Mag Coupling - ST STL	2 SPDT MECH, & Transmitter, 304 Stainless Steel	10 amps / 4-20 mA out

*No Visual Indicator Mag (Magnetic) Coupling - Maximum hazard protection and submersible. Prox (Proximity) sensors are all Herm (Hermetically) Sealed Reeds. Anodized aluminum housing is standard. 316 Stainless Steel is optional.

** Conbraco maintains the 12ADO in stock, Conbraco part number with indicator M116100 and without indicator M105900.

When ordering, please specify requirements for explosion proof certifications (US, CSA OR CENELEC), or Intrinsic Safety. Standard temperature (180°F) switches are available. White epoxy is optional. When you need a junction package, specify your solenoid valve requirement(s). For factory sealed lead orders, please specify number of leads and desired length (36" standard). Let us know if you need special cables or connectors, and specify your mounting hardware requirements.

OSHA LOCKOUT DEVICE



The Apollo® Lockout Tagout accessory for actuators complies with OSHA 1910.147 guidelines. It insures complete lockout capability in both the fully open or the fully closed position. Its design prevents accidental or malicious tampering of an automated valve's orientation.

The housing is constructed in investment cast 316SS, the fasteners, the lock pin, and the coupling are made of 300 Series stainless steel. This rugged construction, plus two acetal bushings located above and below the coupling, assures the strength and support necessary to withstand the torque and torsion generated by the actuator mounted above.

The top and bottom of the housing feature ISO 5211 mounting patterns. This design allows the accessory to be fitted between existing actuators and stainless steel bracketry that also comply with the ISO 5211 standard.

Available in six sizes, it is the perfect compliment to the Apollo® Rack and Pinion Actuator and Apollo® Ball Valve. The design results in a safe automated package that will satisfy the concerns of the most discriminating safety engineer.

The lockout device may be used with electric actuators. However, caution should be exercised due to the possibility of motor burnout in an energized and locked position.

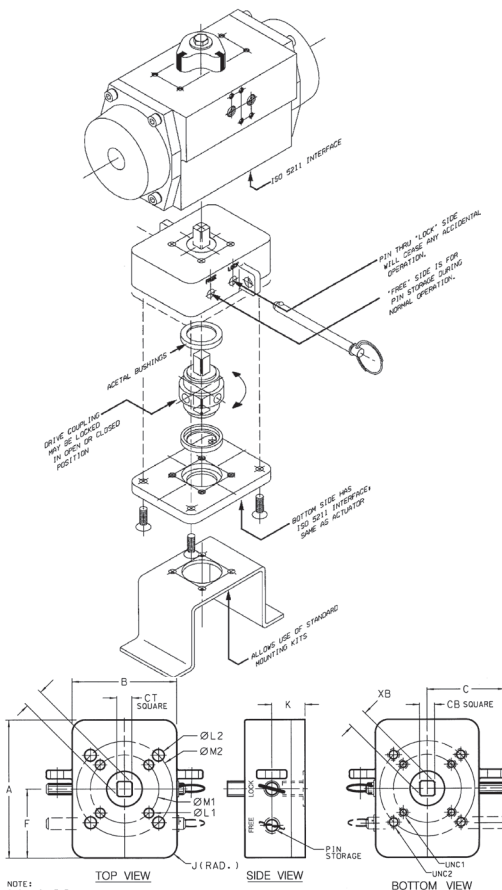

DIMENSION	3TL3000	3TL4000	3TL5060	3TL6570	3TL8000	3TL9000
A	4.00	4.00	6.00	6.00	8.00	8.00
B	3.00	3.00	4.25	4.25	6.00	6.00
C	2.25	2.25	3.12	3.12	4.25	4.25
D	1.75	1.75	2.37	2.37	3.50	3.50
E	0.06	0.06	0.10	0.10	0.18	0.18
F	2.00	2.00	3.00	3.00	4.00	4.00
G	0.50	0.70	0.87	0.87	1.38	1.38
H	1.02	1.02	1.75	1.75	2.50	2.50
I	0.62	0.70	1.17	1.17	2.00	2.00
J(RAD.)	0.37	0.37	0.50	0.50	0.75	0.75
K	0.96	0.96	1.50	1.50	2.50	2.50
L1	0.265	0.265	0.328	0.328	0.515	0.640
L2	NA	NA	0.390	0.390	NA	NA
UNC1	1/4-20UNC	1/4-20UNC	5/16-18UNC	5/16-18UNC	1/2-20UNC	5/8-11UNC
UNC2	NA	NA	0.390	0.390	NA	NA
M1 B.C.	1.970 (F05)	1.970 (F05)	2.756 (F07)*	2.756 (F07)	4.920 (F12)	5.510 (F14)
M2 B.C.	NA	NA	4.016 (F10)	4.016 (F10)*	NA	NA
XT (MAX.)	0.540	0.690	0.955	1.080	1.325	1.780
XB (MIN.)	0.551	0.710	0.985	1.105	1.420	1.890
CT	.430/.432	.547/.550	.744/.747	.862/.865	1.056/1.059	1.413/1.416
CB	.433/.435	.551/.553	.748/.750	.866/.868	1.060/1.063	1.419/1.422
WEIGHT	3.65	3.75	9.90	10.40	28.90	29.50

*F Patterns Designated are Conbraco's Standard Mounting Arrangement

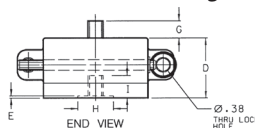

APOLLO® BALL VALVES

VALVE MOUNTING

Mounting of Apollo® actuators to quarter turn valves is a straight forward task. Conbraco provides stainless steel brackets and couplings that are precision made to fit each of its Apollo® valve and actuator combinations. The simplicity of valve mounting hardware is deceptive and may cause carelessness in the assembly operation.

CAUTION

It is mandatory that the actuator to valve mounting procedure be performed by personnel that have been properly trained and informed of the importance of this assembly operation.

Conbraco's brackets and couplings have been engineered to have the required strength and precision fit to insure reliable valve operation. Each mounting kit has all the required components to mate specific valves and actuators (refer to the mounting kit selection guide).

CAUTION

Brackets and couplings of lesser quality can expose the stem of the valve to side loads that will ultimately cause premature stem leakage. It is essential that the actuator to valve mounting be treated as a critical assembly operation. All brackets and couplings must be properly aligned prior to tightening the attachment bolts. The assembly should undergo an operational test to insure that there is no binding during operation. There must be no discernible flexing of the bracket. If either is noted corrective action must be taken before the assembly is considered acceptable for use.

ALL AUTOMATED VALVES must undergo an operational test to insure that both the valve and actuator function properly. The valve must be properly aligned in both the open and closed positions. Spring return actuators must perform their intended safety function such as: fail closed, fail open. Modulating actuators should operate the valve in the correct direction in response to the required instrument signal.

BALL VALVE TORQUE

Before an actuator can be selected, the in-service torque requirement of the valve must be determined. The in-service valve torque is influenced by many factors. Packing and seating materials are fundamental to the construction of the valve and therefore establish the basic required torque. Service conditions which include differential pressure, frequency of operation and flow media also have a significant effect on the valve's in-service torque. Refer to the Torque Constants Chart for valve torque requirements under defined conditions. The torque required to operate a ball valve is the result of friction between the moving and stationary components of the valve. The stem to packing friction and the ball to seat friction combine to establish the minimum torque requirement. **Conbraco recommends the use of a stainless steel ball and stem on automated valves.**

LONG STAND STILL TORQUE (LSST)

Common to soft seated ball valves is the phenomena of Long Stand Still Torque (LSST). For floating ball valves, LSST is typically twice the normal rated torque. The phenomena occurs when a valve remains idle for an extended period of time, typically a month or more, but the time period can vary by application. Even if "normal" operation is daily or even more frequent, if the valve sits idle LSST still need to be taken into account when sizing an actuator. Once the valve has been operated a couple of times, the operating torque returns to normal levels.

APOLLO® BALL VALVES

BALL & SEAT

Valve torque is primarily dependent on the friction between the moving ball and the stationary seat. Seating material and surface finish of the ball establish the basic frictional characteristics of the combination. Service conditions also play a major roll in modifying the effects of friction. A floating ball valve utilizes the difference between the upstream and downstream pressures to force the ball into the downstream seat. When this force exceeds the forces in the original assembly, the torque required to rotate the ball increases. Process media may also increase or decrease the friction between the ball and seat. To insure reliable actuator selection, the service conditions of the installed valve must be carefully determined and considered for their effect on torque.

STEM & PACKING

Stem torque is primarily dependent on the frictional characteristics of the packing material and the tightness of the packing adjustment. Proper adjustment of the packing is important not only to the leak tight performance of the valve but also minimizes the operating torque. Tightening the packing more than is required to establish a proper seal, only increases torque requirements and stem wear. Packing adjustment can be abused to the point that a properly selected actuator may not be able to operate the valve. Stem packing friction is essentially unaffected by the media and operating pressures within the valve.

-24/-29 GRAPHITE STEM PACKING ADDER

The selection of graphite packing contributes significantly to the operating torque of a valve. The friction factor for graphite is a magnitude different than that of PTFE based packings. The contribution to torque is a function of the stem diameter and is reflected in each of the following tables. When selecting either the -24, -29 or -65 options use the appropriate adder listed in the table for each valve as a direct increase to the base torque constant.

BREAKWAY TORQUE

Torque required to initiate the opening of a valve from the fully closed position. This is the highest torque requirement anywhere within the Apollo® Ball Valve's rotation. The Torque Constants Chart lists breakaway torques for Apollo® valves under defined operation conditions.

Note: For double acting actuators, the torque output at the given air supply pressure must exceed the breakaway torque of the valve.

CLOSING TORQUE

Torque required to rotate the valve from the open position, into the fully closed position. A conservative approach is taken when determining closing torque because operating conditions have a significant effect on its value. It is safest to assume that closing torque is equal to breakaway torque. In actual service conditions the closing torque may be less, but this margin is used as a sizing safety factor.

GUIDELINES FOR DETERMINING IN-SERVICE VALVE TORQUE

Actual service conditions must be considered when determining a valve's required torque. Torque Adjustment Factors have been established to convert the Torque Constant value to an in-service torque. Multiple Torque Adjustment Factors may be required to establish the proper in-service torque requirement. All valve torque determinations begin with the Torque Constant value at the appropriate differential pressure. Adjustment factors must be used to determine the in-service valve torque requirement (see page 52, Torque Adjustment Factors Chart). Each applicable adjustment factor is applied to the value from the Torque Constants chart. The sum of all appropriate adjustments of the valve's torque are added to the original value from the Torque Constants chart. The result is the in-service torque requirement. This torque value is to be used in actuator selection.

Note: For fail closed applications, the closing torque must be exceeded by the "spring end" force of the actuator. For fail open applications, the closing torque must be exceeded by the "air end" (at the given supply pressure) force of the actuator.

APOLLO® BALL VALVES

TORQUE CONSTANTS FOR APOLLO END ENTRY VALVE (1), (2)

TORQUE CONSTANT (LB-IN) AT DIFFERENTIAL PRESSURE INDICATED (PSIG)									
Differential Pressure (psig)		200	400	600	800	1000	1500	LSST***	-24/-29 Adder
Valve Model	Size							(in.-lbs)	(in.-lbs)
STD PORT 70-64X 71-14X 76-10X 76-60X 89-14X 399-10X	1/4 - 1/2	35	35	40	43	46	48	70	45
	3/4	50	50	54	59	62	64	100	45
	1	101	101	103	106	116	130	202	56
	1-1/4	171	171	205	216	246	286	342	96
	1-1/2	192	192	216	265	280	311	384	96
	2	271	271	276	300	309	354	542	96
	2-1/2 & 3	715	715	790		1200		1430	96
FULL PORT BRONZE 77-14X	1/4 - 1/2	35	35	40				70	45
	3/4	74	74	84				148	56
	1	234	234	250				468	56
	1-1/4	286	286	321				552	56
	1-1/2	357	357	398				714	96
	2	650	650	722				1300	96
	2-1/2 & 3	715	715	790				1430	111
FULL PORT BRONZE 77D-14X	1/2	25	25	25	25			50	
	3/4	55	55	55	55			110	
	1	87	87	87	87			174	
	1-1/2	120	120	120	120			240	
	2	280	280	280	280			560	
**STD PORT **71-ARX-64 89-ARX-64 76-ARX-64	1/4 - 1/2	26	27	28	30	32	35	50	45
	3/4	50	52	54	57	60	64	100	45
	1	86	88	90	94	97	110	170	56
	1-1/4	140	145	156	160	172	194	280	96
	1-1/2	164	173	186	195	201	235	320	96
	2	230	258	270	310	350	460	440	96
	2-1/2	495	576	680	790	900		900	96
	3	540	700	820	920	1030		1000	96
*FULL PORT **77-ARX-64	1/4 - 1/2	50	52	54				100	45
	3/4	86	88	90				170	56
	1	148	160	180				280	56
	1-1/2	300	310	340				580	96
	2	355	420	563				680	96
FULL PORT 3-PIECE 82-14X & 24X	1/4 - 1/2	78	78	90				156	56
	3/4	156	156	178				312	56
	1	208	208	230				416	96
	1-1/4	234	234	276				468	96
	1-1/2	350	350	390				700	96
	2	715	715	755				1430	96
	3	710						1100	292
4	1052						1540	292	
FULL PORT 3-PIECE 83A-14X & 24X 83B-14X & 24X 86A-10X & 20X 86B-10X & 20X	1/4 - 1/2	38	39	41	42	43	49	75	45
	3/4	61	62	63	63	67	79	121	68
	1	97	104	110	117	124	141	180	68
	1-1/4	182	198	213	228	243	281	335	96
	1-1/2	182	198	213	228	243	281	335	96
	2	275	388	402	466	529	688	422	127
FULL PORT 3-PIECE 83R-108-01 & 83R-100-01 86R-108-01 & 86R-100-01	2	715	715	755	800	912	1024	1430	96
	3	1030	1030	1087	1148	1212		2060	201

* Torques tested with multifilled seats. Does not require torque adjustment of -20%.

** 71-ARX-64 and 77-ARX-64 rated to 600 psig maximum.

*** LSST - Long Stand Still Torque

Note 1:
Constants are used to determine the in-service torque requirements of Apollo Valves.
Note 2:
Constants are based on RPTFE seats, and clean dry air at the stated differential pressure.

APOLLO® BALL VALVES

TORQUE CONSTANTS FOR APOLLO PEEK SEATED 83B/86B WITH GRAPHITE STEM PACKING

TORQUE CONSTANT (LB-IN) AT DIFFERENTIAL PRESSURE INDICATED (PSIG)										
Differential Pressure (psig):		200	400	600	800	1000	1200	1400	1500	LSST
Valve Model	Size									(in.-lbs)
FULL PORT 3-PIECE	1/4 - 1/2	75	80	86	91	98	105	111	118	112
	3/4	130	150	170	177	185	194	204	210	195
	1	250	263	276	289	302	315	328	345	375
83B/86B	1-1/4	420	463	506	549	592	635	678	720	630
	1-1/2	420	463	506	549	592	635	678	720	630
	2	840	922	1004	1086	1168	1250	1332	1410	1260

Caution: 2" PEEK seated valves operating at pressures higher than 1000 psig. should be automated or have a gear operator installed. Lever operation is not suggested. All values are stated in (in. lbs.)

TORQUE CONSTANTS FOR APOLLO FLANGED BALL VALVES

Valve Series	Size	WORKING PRESSURE (PSIG)											
		0	100	200	300	400	500	600	700	740	LSST (in.-lbs)	-24 Adder (in.-lbs)	
87A-100'S 88A-140'S 87B-100'S 88B-100'S	1-1/2" SP 150	132	144	155	167							264	68
	2" SP 150	176	193	211	228							352	96
	2-1/2" SP 150	231	254	277	300							462	127
	3" SP 150	253	327	402	476							506	127
	4" SP 150	850	860	875	890							1700	292
	6" SP 150	1325	1345	1370	1400							2650	292
	8" SP 150	2200	2494	2788	3081							4400	661
87A-200'S 88A-240'S	10" SP 150	3300	3580	3860	4140							6600	661
	1/2" FP 150	22	22	22	22							44	45
	3/4" FP 150	39	43	47	51							77	68
	1" FP 150	132	144	155	167							264	68
	1-1/2" FP 150	176	193	211	228							352	96
	2" FP 150	231	254	277	300							462	127
	2-1/2" FP 150	253	327	402	476							506	127
	3" FP 150	850	860	875	890							1700	292
	4" FP 150	1325	1345	1370	1400							2650	292
	6" FP 150	2200	2494	2788	3081							4400	661
	8" FP 150	3300	3580	3860	4140							6600	661
87A-700'S 88A-740'S	10" FP 150	4400	5059	5718	6377							8800	988
	12" FP 150	4950	8300	11650	15000							9900	988
	1-1/2" SP 300	132	144	155	167	178	190	201	213	217		264	68
	2" SP 300	176	193	211	228	245	262	280	297	304		352	96
	2-1/2" SP 300	231	254	277	300	323	346	369	392	401		462	127
	3" SP 300	253	327	402	476	551	625	700	774	804		506	127
	4" SP 300	850	860	875	890	910	950	1030	1110	1142		1700	292
	6" SP 300	1325	1345	1370	1400	1430	1474	1615	1756	1812		2650	292
8" SP 300	2200	2494	2788	3081	3375	3669	3963	4257	4374		4400	661	
87A-900'S 88A-940'S	10" SP 300	3300	3580	3860	4140	4420	4700	4980	5260	5372		6600	661
	1/2" FP 300	22	22	22	22	23	23	23	23	23		44	45
	3/4" FP 300	39	43	47	51	55	59	63	67	69		77	68
	1" FP 300	132	144	155	167	178	190	201	213	217		264	68
	1-1/2" FP 300	176	193	211	228	245	262	280	297	304		352	96
	2" FP 300	231	254	277	300	323	346	369	392	401		462	127
	2-1/2" FP 300	253	327	402	476	551	625	700	774	804		506	127
	3" FP 300	850	860	875	890	910	950	1030	1110	1142		1700	292
	4" FP 300	1325	1345	1370	1400	1430	1474	1615	1756	1812		2650	292
	6" FP 300	2200	2494	2788	3081	3375	3669	3963	4257	4374		4400	661
	8" FP 300	3300	3580	3860	4140	4420	4700	4980	5260	5372		6600	661
	10" FP 300	4400	5059	5718	6377	7036	7696	8355	9014	9277		8800	988
12" FP 300	4950	8300	11650	15000	18349	21699	25049	28399	29739		9900	988	



APOLLO® BALL VALVES

TORQUE CONSTANTS FOR APOLLO CLASS 600 FULL PORT FLANGED VALVES

Seat Material	size	working pressure (psig)									-24 ADDER
		200	400	600	800	1000	1200	1400	1500	LSST*	
Devlon V-API (-95)	1"	166	189	211	233	256	275	292	300	288	N/A
	1.5"	253	273	292	312	331	351	370	380	468	N/A
	2"	686	698	710	721	732	744	755	761	1350	N/A
	2.5"	1150	1190	1231	1272	1313	1353	1395	1415	2256	N/A
	3"	1893	2030	2167	2304	2440	2577	2714	2782	3512	N/A
	4"	2406	2681	2957	3232	3508	3784	4060	4197	4260	N/A
	6"	7935	8280	8625	8970	9135	9660	10005	10178	13638	N/A
PEEK (-38)	8"	8282	8868	9454	10041	10627	11213	11799	12092	15978	N/A
	1"	184	204	224	245	264	283	304	314	328	N/A
	1.5"	379	399	420	439	460	479	500	509	468	N/A
	2"	882	968	1054	1140	1225	1313	1399	1481	1323	N/A
	2.5"	1256	1320	1384	1448	1512	1576	1640	1672	2384	N/A
	3"	2378	2588	2797	3007	3217	3427	3637	3741	4336	N/A
	4"	5771	6832	7892	8952	10012	11073	12133	12663	9422	N/A
UHMWPE (-21)	6"	6983	8675	10368	12061	13753	15446	17139	17985	10580	N/A
	8"	8586	12822	17058	21294	25531	29767	34003	36121	12936	N/A
	1"	155	178	201	219	222	224	228	228	264	N/A
	1.5"	211	245	280	305	310	315	318	318	352	N/A
	2"	428	454	479	505	531	556	582	594	806	N/A
	2.5"	447	467	486	506	525				875	N/A
	3"	1139	1224	1310	1396	1482				2106	N/A
MULTISEAL (-80)	4"	1506	1638	1820	2002	2184				2600	N/A
	6"	3133	3487	3842						5558	N/A
	8"	3814	4354	4894						7088	N/A
	1"	155	180	205	222	227	231	233	234	264	102
	1.5"	213	245	280	308	316	322	326	326	354	144
	2"	313	356	400	444	487	531	575	597	538	191
	2.5"	410	437	465	493	520				791	191
3"	875	890	1030	1151	1228				1112	292	
4"	1506	1584	1683	1781	1880				2776	292	
6"	2788	3375	3963						4824	661	
8"	4836	5175	5514						8993	988	

Caution: For torque constants in the highlighted areas, manual valve operation is not suggested. Automated and gear operated assembly options are available. All values are stated in (in. lbs)

APOLLO® BALL VALVES

BALL VALVE TORQUE ADJUSTMENT FACTORS

PROVISION	CONDITION	FACTOR
TYPE OF OPERATION	ON/OFF SERVICE	0
	MODULATING SERVICE	0.25
PROCESS MEDIA	LIQUID, CLEAN PARTICLE FREE	0
	LIQUID, DIRTY, SLURRY, RAW WATER	0.3 to 0.8
	LIQUID, BLACK LIQUOR, LIME SLURRY	0.8
	LIQUID, OIL, LUBRICATING	0
	LIQUID, VISCOUS, MOLASSES	0.3
	GAS, CLEAN & WET	0
	GAS, DRY	0.3 to 0.5
	GAS, DIRTY, AIR SLURRY, NATURAL GAS	0.5 to 1
	OXYGEN, CHLORINE	0.5
	SUPERHEATED STEAM, SATURATED STEAM	Refer to Process Temp.
FREQUENCY OF OPERATION**	ONCE PER DAY OR MORE	0
	ONCE PER WEEK	0.2
	ONCE PER MONTH	0.5
	Less than once per month (LSST)	1
PROCESS TEMPERATURE	APPLICATIONS ABOVE 225 DEG F	0.50
	APPLICATIONS BELOW -20 DEG F	0.25
VALVE SEATING MATERIAL	PTFE	0
	*MULTIFILL	0
	*PEEK	Contact Factory
	*UHMWPE	Contact Factory
OPTION	LIVE LOADED VALUES	0.2
	-49 ASSEMBLED DRY	0.3
	-57 OXYGEN CLEANED	0.3
	-67 CLEANED FOR INDUSTRIAL GAS	0.3
	-90 DOUBLE PACKED EXTENDED BONNET	0.2
CUSTOMER SPECIFIED	PRESCRIBED SAFETY FACTOR	0.2 to 2

Example:

To find adjusted torque:

1" 76-AR5-64 used on Oxygen service once per week to once per month. Find the torque constant of the valve at 200 psig DP, then add together the adjustment factors, and add 1 to that number. Then multiply the sum of the adjustment times the torque.
 $86'' \text{ lbs} \times (.5 + .5 + 1) = 172'' \text{ lbs. adjusted torque.}$

* Do not consider when calculating Top Entry Valve Torques. Apply all applicable Torque Adjustment Factors to the Valve
 ** If accounting for LSST, disregard frequency of operation.

TORQUE CONSTANTS FOR TOP ENTRY BALL VALVES

Seats	Valve Size Std. Port (Inches)	Valve Size Full Port (Inches)	Differential Pressures (psig) (In.-Lbs.)						Grafoil® Adder
			100	285	500	740	1480	LSST*	
5	1/2 thru 1	1/2 thru 3/4	85	110	140	180	290	170	68
6**	1-1/2	1	205	260	330	415	660	410	96
C	2	1-1/2	350	430	550	735	1,200	700	127
D	3	2	950	1,250	1,650	2,000	3,200	1,900	245
G	4	3	2,000	2,500	3,300	4,100	6,500	4,000	399
L	6††	4††	5,300	6,700	8,200	11,400	18,000	10,600	661
M	8††	6††	11,000	14,000	18,500	25,000	36,000	22,000	900
U**	10††	8††	18,500	22,000	30,000	40,000	62,000	37,000	1,326
	1/2 thru 1	1/2 thru 3/4	115	160	210	260	450	230	68
4	1-1/2	1	270	370	480	590	1,000	540	96
8	2	1-1/2	475	650	860	1,050	1,750	950	127
9	3	2	1,250	1,850	2,400	2,950	4,900	2,500	245
B	4††	3††	2,700	3,700	4,900	5,900	10,000	5,400	399
H	6††	4††	7,410	10,100	13,400	16,400	25,300	14,800	661
N	8††	6††	15,000	20,000	26,000	34,500	56,000	30,000	900
	10††	8††	25,000	32,000	45,000	60,000	96,000	50,000	1,326

*LSST - Long Stand Still Torque

**Rated torque for #6 and U seat add 30%

†Rated torque for #9 ceramic seat is to be increased by 10%

††Gear operator or actuation recommended



APOLLO® BUTTERFLY VALVES

BUTTERFLY VALVE ACTUATOR SIZING PROCEDURES

DOUBLE ACTING ACTUATOR:

AIR TO OPEN, AIR TO CLOSE

- ✓ Choose an actuator whose output torque at the given air supply is greater than the butterfly valve's seating/unseating torque.
- ✓ Unseating torque is also known as the breakaway torque.
- ✓ Seating torque is also known as the closing torque.

SPRING RETURN FAIL CLOSED:

AIR TO OPEN, SPRING TO CLOSE

- ✓ Select an actuator whose ending spring stroke is greater than the butterfly valve's seating/unseating torque.
- ✓ Select an actuator whose starting air stroke is greater than the butterfly valve's seating/unseating torque at the given air supply pressure.
- ✓ Above must be found on the same spring set line.

SPRING RETURN FAIL OPEN:

AIR TO CLOSE SPRING TO OPEN

- ✓ Select an actuator whose end of air stroke is greater than the butterfly valve's seating/unseating torque at the given air supply pressure.
- ✓ Select an actuator whose start of spring stroke is greater than the butterfly valve's seating/unseating torque.
- ✓ Above must be found on the same spring set line. See Actuator Part Numbering System-"F" Suffix for Fail Open

FACTORS AFFECTING SEATING AND UNSEATING TORQUE AND APPLICATION GUIDELINES

OPERATING FREQUENCY

The first operation of a valve after a sustained period of closure will require above normal torque.

LUBRICATING CHARACTERISTICS OF FLOW MEDIA

Judge your flow media on this basis-better than or worse than water. Examples of lubricating media are: water, lubricating oils, aqueous process flow, beverage service, etc. Examples of non-lubricating media are: air, dry gases, dry bulk services, solvents, diesel oil, etc.

CONDITION OF DISC EDGE AND SEAT

An iron disc in corrosive service will corrode. This corrosion deposits a build-up on the disk edge and raises required torque. Similar flow media deposits on the seat material can increase torque or prevent proper valve operation.

TEMPERATURE EXTREMES

Sustained operating temperatures approaching the upper or lower limits of the seat material will increase required torque. Refer to the seat temperature range on Apollo® Butterfly Valve Seat Materials page in the catalog. Consult the factory for anticipated torque increase of certain seat materials due to temperature extremes.

ELASTOMER SWELL

Certain elastomers tend to swell from contact with some chemicals. This elastomer swell will increase required torque.

*The wide selection of Apollo® Available Materials of Construction will allow you to choose the correct butterfly valve materials for your service. All of the above **Torque Affecting Factors** can be accommodated with the correct choice of materials. Consult the factory for assistance in choosing the correct torque value for your service.*

NOTE: Please consult the material selection guide for trim recommendations. Please consult the factory for proper sizing of Apollo® actuators.

APOLLO® HIGH PERFORMANCE BUTTERFLY VALVES

TORQUE CONSTANTS FOR APOLLO DOUBLE OFFSET HIGH PERFORMANCE BUTTERFLY VALVES

Soft & UHMWPE Seat – Torque Rating (In-Lbs)

SIZE	PSIG	CLASS 150				CLASS 300					CLASS 600					
		ΔP=100	ΔP=150	ΔP=200	ΔP=285	ΔP=100	ΔP=150	ΔP=200	ΔP=285	ΔP=740	ΔP=150	ΔP=500	ΔP=800	ΔP=1000	ΔP=1200	ΔP=1480
2"	in-lbs	204	230	266	332	248	332	381	425	531	–	–	–	–	–	–
2.5"	in-lbs	239	283	319	398	301	398	443	478	575	–	–	–	–	–	–
3"	in-lbs	257	301	345	434	327	434	487	540	664	407	513	841	974	1,106	1,283
4"	in-lbs	398	469	531	664	469	664	761	867	1,106	620	841	1,540	1,823	2,106	2,487
5"	in-lbs	558	655	743	929	620	885	1,062	1,239	1,664	–	–	–	–	–	–
6"	in-lbs	726	850	974	1,212	858	1,221	1,505	1,779	2,460	974	1,363	2,593	3,089	3,575	4,248
8"	in-lbs	1,328	1,549	1,770	2,213	1,646	2,354	2,921	3,487	4,868	1,912	2,673	5,080	6,045	7,009	8,319
10"	in-lbs	2,213	2,575	2,947	3,682	2,575	3,682	4,691	5,699	8,142	3,177	4,437	8,434	10,036	11,638	13,806
12"	in-lbs	2,867	3,345	3,823	4,779	3,629	5,177	6,522	7,877	11,151	4,788	6,682	12,709	15,116	17,523	20,798
14"	in-lbs	4,938	5,761	6,584	8,231	6,053	8,646	11,186	13,735	19,913	–	–	–	–	–	–
16"	in-lbs	6,903	8,054	9,204	11,505	8,461	12,080	14,788	17,496	24,072	–	–	–	–	–	–
18"	in-lbs	9,717	11,337	12,956	16,196	11,903	17,010	20,461	23,913	32,303	–	–	–	–	–	–
20"	in-lbs	12,930	15,089	17,240	21,550	15,842	22,629	26,816	30,993	41,153	–	–	–	–	–	–
24"	in-lbs	19,859	23,169	26,479	33,099	24,329	34,754	40,595	46,436	60,623	–	–	–	–	–	–
30"	in-lbs	30,090	35,400	40,710	49,472	–	–	–	–	–	–	–	–	–	–	–
36"	in-lbs	48,233	58,145	68,057	84,849	–	–	–	–	–	–	–	–	–	–	–

Fire Safe Seat – Torque Rating (In-Lbs)

SIZE	PSIG	CLASS 150				CLASS 300					CLASS 600					
		ΔP=100	ΔP=150	ΔP=200	ΔP=285	ΔP=100	ΔP=150	ΔP=200	ΔP=285	ΔP=740	ΔP=150	ΔP=500	ΔP=800	ΔP=1000	ΔP=1200	ΔP=1480
2"	in-lbs	434	504	584	726	504	726	770	814	929	–	–	–	–	–	–
2.5"	in-lbs	460	540	620	770	540	770	823	885	1,018	–	–	–	–	–	–
3"	in-lbs	584	681	779	974	681	974	1,035	1,097	1,257	866	1,208	1,549	1,788	2,027	2,354
4"	in-lbs	708	832	947	1,186	832	1,186	1,248	1,319	1,478	1,402	1,887	2,372	2,797	3,230	3,814
5"	in-lbs	965	1,124	1,283	1,602	1,133	1,620	1,894	2,177	2,850	–	–	–	–	–	–
6"	in-lbs	1,345	1,566	1,788	2,239	1,584	2,257	2,531	2,805	3,478	3,758	4,485	5,213	6,204	7,186	8,531
8"	in-lbs	2,089	2,443	2,788	3,487	2,513	3,584	4,160	4,735	6,133	7,077	8,455	9,832	11,691	13,558	16,089
10"	in-lbs	3,283	3,832	4,381	5,478	4,027	5,753	6,673	7,602	9,841	11,400	13,616	15,833	18,833	21,833	25,913
12"	in-lbs	5,168	6,036	6,894	8,620	6,230	8,894	10,470	12,045	15,877	17,542	20,949	24,355	28,975	33,595	39,869
14"	in-lbs	6,912	8,062	9,213	11,514	8,363	11,948	14,426	16,904	22,913	–	–	–	–	–	–
16"	in-lbs	8,770	10,231	11,700	14,620	10,655	15,222	18,682	22,152	30,559	–	–	–	–	–	–
18"	in-lbs	12,567	14,664	16,762	20,948	15,178	21,683	27,541	33,409	47,640	–	–	–	–	–	–
20"	in-lbs	16,859	19,674	22,479	28,099	20,196	28,851	37,993	47,126	69,322	–	–	–	–	–	–
24"	in-lbs	25,072	29,249	33,426	41,781	30,046	42,923	56,622	70,331	103,607	–	–	–	–	–	–

Metal Seat – Torque Rating (In-Lbs)

SIZE	PSIG	CLASS 150				CLASS 300					CLASS 600					
		ΔP=100	ΔP=150	ΔP=200	ΔP=285	ΔP=100	ΔP=150	ΔP=200	ΔP=285	ΔP=740	ΔP=150	ΔP=500	ΔP=800	ΔP=1000	ΔP=1200	ΔP=1480
2"	in-lbs	478	558	637	797	558	797	850	903	1,027	–	–	–	–	–	–
2.5"	in-lbs	513	593	681	850	593	850	912	974	1,124	–	–	–	–	–	–
3"	in-lbs	637	743	850	1,062	743	1,062	1,133	1,204	1,381	832	1,035	1,699	1,965	2,230	2,593
4"	in-lbs	797	929	1,062	1,328	929	1,328	1,398	1,460	1,628	1,496	2,018	3,708	4,381	5,053	5,965
5"	in-lbs	1,062	1,239	1,416	1,770	1,248	1,744	2,089	2,398	2,133	–	–	–	–	–	–
6"	in-lbs	1,487	1,735	1,982	2,478	1,770	2,522	2,814	3,106	2,823	2,947	4,106	7,815	9,301	10,788	12,797
8"	in-lbs	2,257	2,637	3,009	3,761	2,726	3,894	4,540	5,177	6,744	4,443	5,204	11,797	14,036	16,275	19,311
10"	in-lbs	3,797	4,434	5,052	6,328	4,646	6,638	7,584	8,531	10,824	6,558	9,151	17,417	20,718	24,019	28,506
12"	in-lbs	5,947	6,938	7,930	9,912	7,558	10,797	12,302	13,815	17,470	11,001	15,364	29,223	34,772	40,321	47,843
14"	in-lbs	8,655	10,098	11,540	14,426	10,841	15,488	18,196	20,904	27,488	–	–	–	–	–	–
16"	in-lbs	10,965	12,797	14,620	18,275	14,249	20,355	23,691	27,037	35,143	–	–	–	–	–	–
18"	in-lbs	15,718	18,337	20,957	26,196	19,514	27,878	33,949	40,029	54,782	–	–	–	–	–	–
20"	in-lbs	21,081	24,594	28,108	35,135	25,709	36,728	45,648	54,578	76,252	–	–	–	–	–	–
24"	in-lbs	21,382	36,612	41,843	52,304	28,595	55,136	57,251	79,367	108,793	–	–	–	–	–	–

Under certain conditions, hydrodynamic torque can meet or exceed seating and unseating torques. When designing valve systems, hydrodynamic torque must be considered to help ensure correct selection of actuation.



APOLLO® RESILIENT SEATED BUTTERFLY VALVES

SEATING AND UNSEATING TORQUE APOLLO® RESILIENT SEATED BUTTERFLY VALVES WD141, LD141, WD145, LD145, LC149 Series

Valve Size (In.)	Differential Pressure (psid)			
	50 Bushings PTFE	100 Bushings PTFE	150 Bushings PTFE	200 Bushings PTFE
2	100	106	111	117
2 1/2	150	163	176	189
3	207	220	232	244
4	290	323	357	390
5	423	481	540	598
6	599	691	783	875
8	1060	1183	1307	1430
10	1671	1872	2074	2275
12	2568	2795	3023	3250
14	2640	3070	3500	-
16	4260	4880	5500	-
18	6287	7243	8200	-
20	8360	9180	10000	-
24	15427	16813	18200	-
30	31200	32550	33930	-

All torque values shown on chart are for wet (water and other non-lubricating media) on-off service. For dry (non-lubricating, dry gas media), multiply values by 1.15. For lubed service (clean, nonabrasive lubricating media), multiply values by 0.85.

Under certain conditions, hydrodynamic torque can meet or exceed seating and unseating torques. When designing valve systems, hydrodynamic torque must be considered to help ensure correct selection of actuation.

* **ALL PUBLISHED BUTTERFLY TORQUE CHARTS HAVE NO BUILT-IN SAFETY FACTORS.**
A PRESCRIBED 25% SAFETY FACTOR IS RECOMMENDED!

WARRANTY AND LIMITATIONS OF LIABILITY



Conbraco Industries, Inc. warrants, to its initial purchaser only, that its products which are delivered to this initial purchaser will be of the kind described in the order or price list and will be free of defects in workmanship or material for a period of FIVE years from the date of delivery to you, our initial purchaser. This warranty applies to Apollo brand product with "Made in the USA" markings only.

Should any failure to conform to this warranty appear within **FIVE** years after the date of the initial delivery to our initial purchaser, Conbraco will, upon written notification thereof and substantiation that the goods have been stored, installed, maintained and operated in accordance with Conbraco's recommendations and standard industry practice, correct such defects by suitable repair or replacement at Conbraco's own expense.

APOLLO INTERNATIONAL PRODUCTS: Conbraco Industries, Inc. warrants its International products, to its initial purchaser only, that its international products which are delivered to this initial purchaser will be of the kind described in the order or price list and will be free of defects in workmanship or material for a period of **TWO** years from the date of delivery to you, our initial purchaser.

THIS WARRANTY IS EXCLUSIVE AND IS IN LIEU OF ANY IMPLIED WARRANTY OF MERCHANTABILITY, FITNESS FOR A PARTICULAR PURPOSE OR OTHER WARRANTY OF QUALITY, WHETHER EXPRESSED OR IMPLIED, EXCEPT THE WARRANTY OF TITLE AND AGAINST PATENT INFRINGEMENT. Correction of non-conformities, in the manner and for the period of time provided above, shall constitute fulfillment of all liabilities of Conbraco to our initial purchaser, with respect to the goods, whether based on contract, negligence, strict tort or otherwise. It is the intention of Conbraco Industries, Inc. that no warranty of any kind, whether expressed or implied shall pass through our initial purchaser to any other person or corporation.

LIMITATION OF LIABILITY: Conbraco Industries, inc. SHALL NOT UNDER ANY CIRCUMSTANCES BE LIABLE FOR SPECIAL OR CONSEQUENTIAL DAMAGES SUCH AS, BUT NOT LIMITED TO, DAMAGES OR TO LOSS OF OTHER PROPERTY OR EQUIPMENT, LOSS OF PROFITS OR REVENUE, COST OF CAPITAL, COST OF PURCHASED OR REPLACEMENT GOODS, OR CLAIMS OF CUSTOMERS OF OUR INITIAL PURCHASER. THE REMEDIES OF OUR INITIAL PURCHASER, AND ALL OTHERS, SET FORTH HEREIN, ARE EXCLUSIVE, AND THE LIABILITY OF CONBRACO WITH RESPECT TO SAME SHALL NOT, EXCEPT AS EXPRESSLY PROVIDED HEREIN, EXCEED THE PRICE OF THE GOODS UPON WHICH SUCH LIABILITY IS BASED.

* It is the end user's responsibility to confirm that items intended for use satisfy local codes and standards.



Regional Management List now available online at <http://conbra.co/rmlist>



704.841.6000
CUSTOMER SERVICE

www.apollovalves.com

**Elkhart Products
Corporation**



800.395.7313
CUSTOMER SERVICE

www.elkhartproducts.com

LASCO[®]
Fittings, Inc.

800.776.2756
CUSTOMER SERVICE

www.lascofittings.com